

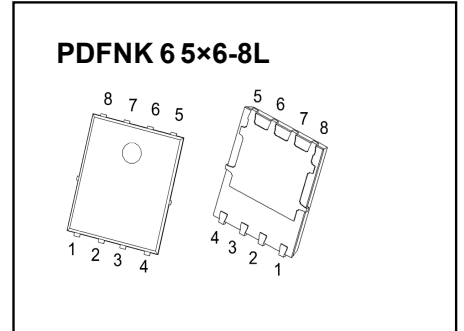

PDFNWB5×6-8L Plastic-Encapsulate MOSFETS

AC130SN06L N-Channel Power MOSFET

$V_{(BR)DSS}$	$R_{DS(on)TYP}$	I_D
60V	2.6mΩ@10V	130A
	3.5mΩ@4.5V	



DESCRIPTION

The AC130SN06L uses shielded gate trench technology and design to provide excellent $R_{DS(ON)}$ with low gate charge. It can be used in a wide variety of applications.

FEATURES

- High Power and current handing capability
- Load switch
- High density cell design for ultra low $R_{DS(ON)}$
- Lead free product is acquired
- Good stability and uniformity with high E_{AS}
- Excellent package for good heat dissipation

APPLICATIONS

- SMPS and general purpose applications
- Hard switched and high frequency circuits
- Uninterruptible Power Supply
- Power management

MARKING



AC130SN06L = Part No.
 Solid dot=Pin1 indicator.
 XX= Code.

EQUIVALENT CIRCUIT

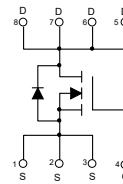

ABSOLUTE MAXIMUM RATINGS ($T_a=25^\circ\text{C}$ unless otherwise noted)

Parameter	Symbol	Value	Unit
Drain-Source Voltage	V_{DS}	60	V
Gate-Source Voltage	V_{GS}	±20	
Continuous Drain Current	I_D ①	130	A
Pulsed Drain Current	I_{DM} ②	390	
Maximum Power Dissipation	P_D ①	130	W
Single Pulsed Avalanche Energy	E_{AS} ③	500	mJ
Thermal Resistance from Junction to Ambient	$R_{\theta JA}$ ⑥	62	$^\circ\text{C/W}$
Thermal Resistance from Junction to Case	$R_{\theta JC}$ ①	0.96	$^\circ\text{C/W}$
Operating Junction and Storage Temperature Range	T_J, T_{stg}	-55~+150	$^\circ\text{C}$

MOSFET ELECTRICAL CHARACTERISTICS

$T_a=25\text{ }^\circ\text{C}$ unless otherwise specified

Parameter	Symbol	Test Condition	Min	Type	Max	Unit
Static Characteristics						
Drain-source breakdown voltage	$V_{(BR)DSS}$	$V_{GS} = 0V, I_D = 1mA$	60			V
Zero gate voltage drain current	I_{DSS}	$V_{DS} = 48V, V_{GS} = 0V$	$T_J = 25\text{ }^\circ\text{C}$		1.0	μA
			$T_J = 125\text{ }^\circ\text{C}$		100	μA
Gate-body leakage current	I_{GSS}	$V_{GS} = \pm 20V, V_{DS} = 0V$			± 100	nA
Gate threshold voltage ^④	$V_{GS(th)}$	$V_{DS} = V_{GS}, I_D = 250\mu A$	1.0	1.6	2.5	V
Drain-source on-resistance ^④	$R_{DS(on)}$	$V_{GS} = 10V, I_D = 20A$		2.6	3.2	m Ω
		$V_{GS} = 4.5V, I_D = 20A$		3.5	4.6	
Dynamic characteristics ^⑤						
Total gate charge	Q_g	$V_{DS} = 30V, V_{GS} = 10V, I_D = 25A$		66.4		nC
Gate-source charge	Q_{gs}			8.5		
Gate-drain charge	Q_{gd}			16.6		
Input Capacitance	C_{iss}	$V_{DS} = 30V, V_{GS} = 0V, f = 100kHz$		3560		pF
Output Capacitance	C_{oss}			1530		
Reverse Transfer Capacitance	C_{rss}			82		
Gate resistance	R_g	$f = 1MHz$		1.5		Ω
SWITCHING PARAMETERS ^⑤						
Turn-on delay time	$t_{d(on)}$	$V_{GS} = 10V, V_{DS} = 30V,$ $R_G = 10\Omega, R_L = 2.1\Omega$		46		ns
Turn-on rise time	t_r			70		
Turn-off delay time	$t_{d(off)}$			106		
Turn-off fall time	t_f			98		
Source-Drain Diode characteristics						
Body diode voltage	V_{SD} ^④	$I_S = 30A, V_{GS} = 0V$			1.3	V

Notes:

- $V_{GS} < 20V$ Limited only by maximum temperature allowed.
- $P_w \leq 10\mu s$, Duty cycle $\leq 1\%$.
- EAS condition: $V_{DD} = 30V, V_{GS} = 10V, L = 0.5mH, R_g = 25\Omega$ Starting $T_J = 25\text{ }^\circ\text{C}$.
- Pulse Test : Pulse Width $\leq 300\mu s$, duty cycle $\leq 2\%$.
- Guaranteed by design, not subject to production.
- The value of $R_{\theta JA}$ is measured with the device mounted on 1 in² FR-4 board with 2oz. Copper, in a still air environment with $T_a = 25\text{ }^\circ\text{C}$.

Typical Characteristics

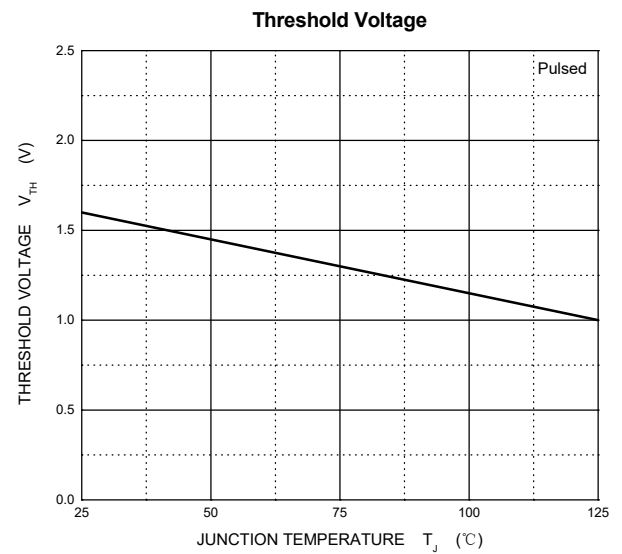
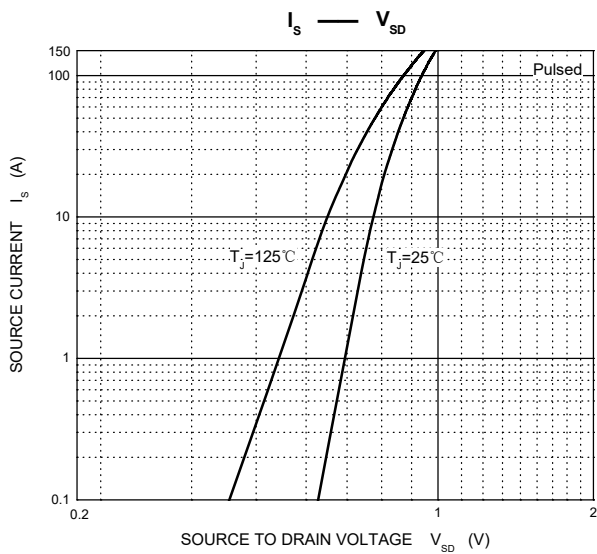
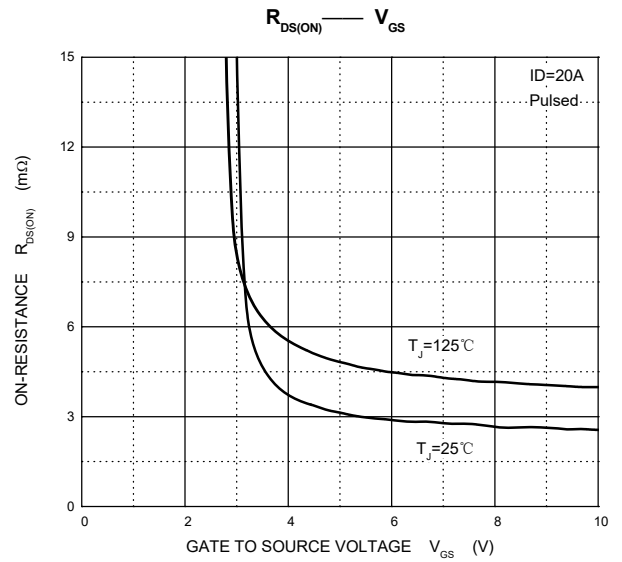
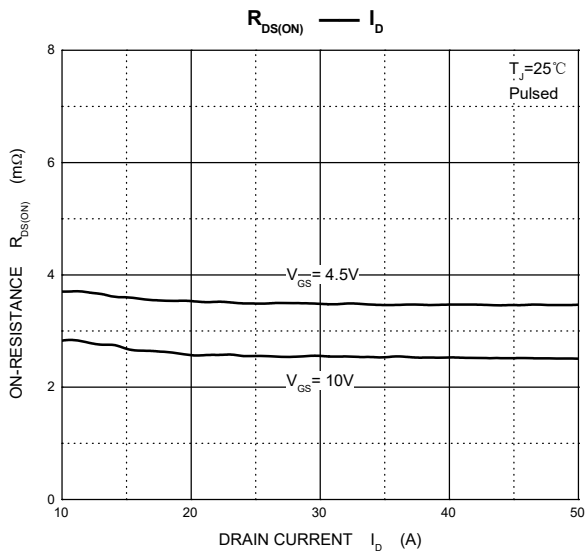
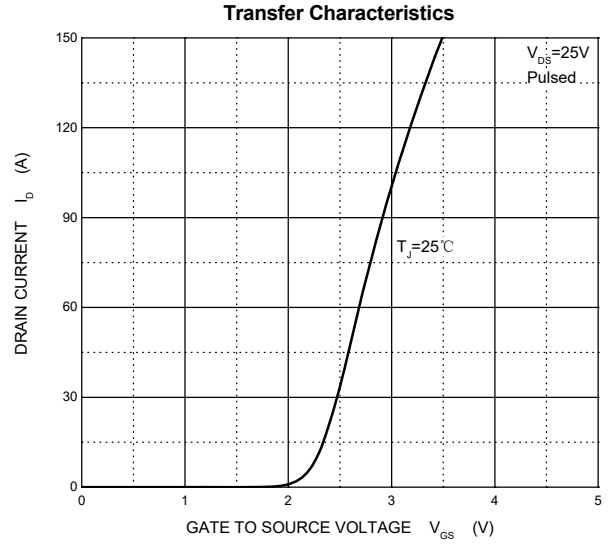
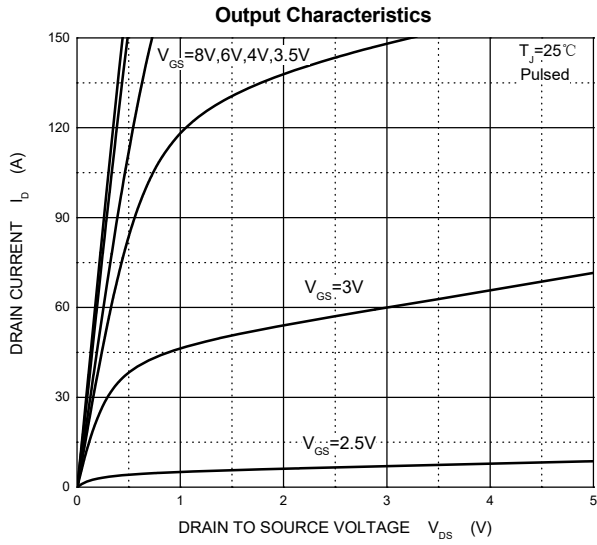

Typical Characteristics

Capacitances

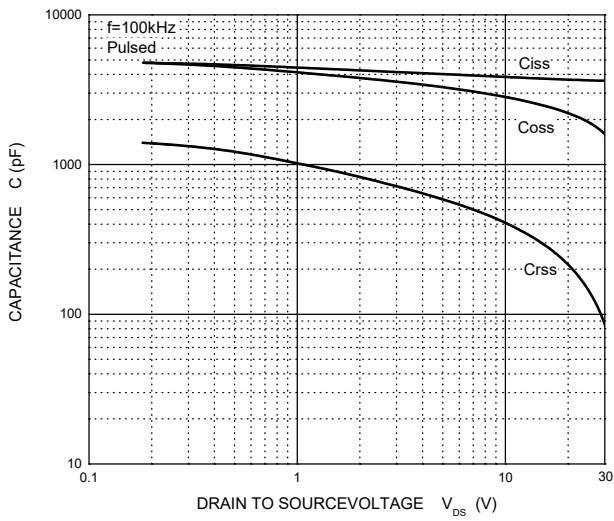

Gate Charge

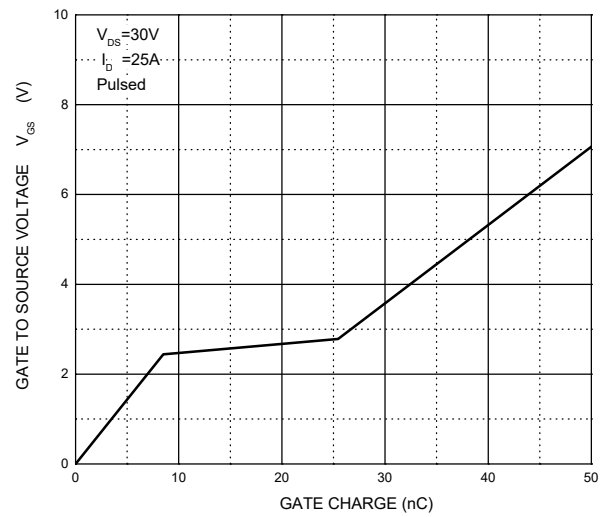

NORMALIZED TRANSIENT THERMAL IMPEDANCE

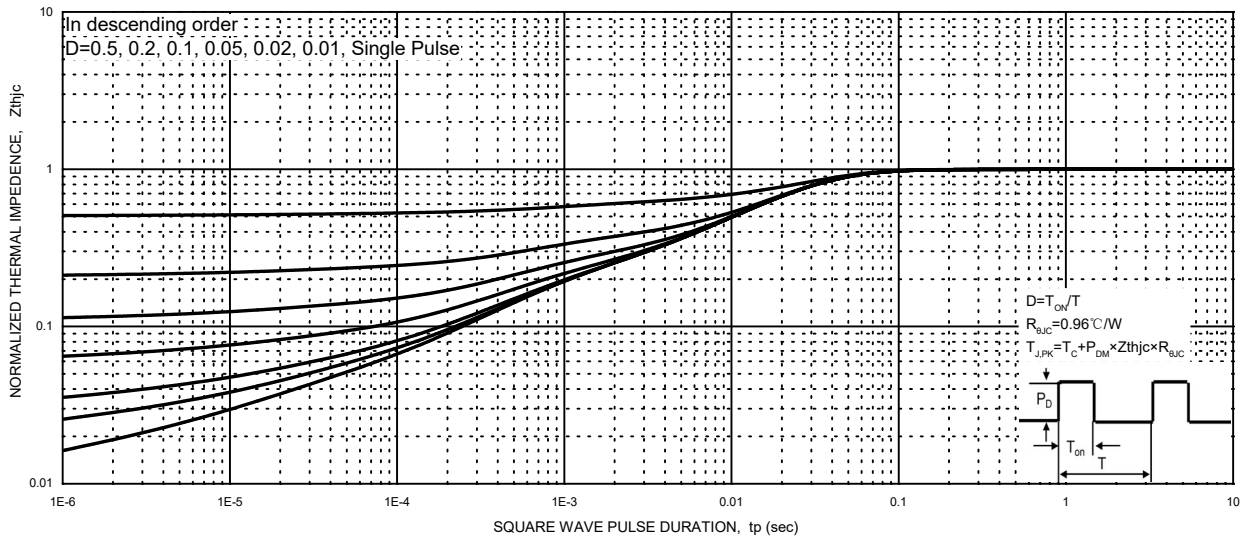

MAXIMUM FORWARD BIASED SAFE OPERATING AREA

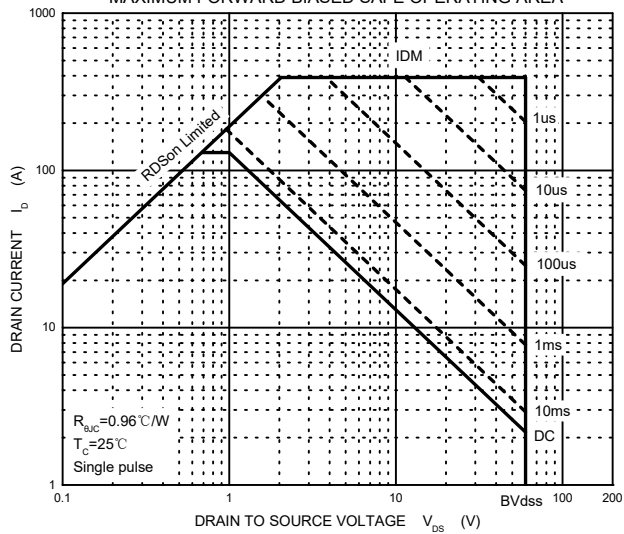

PDFNWB5x6-8L-B Package Outline Dimensions

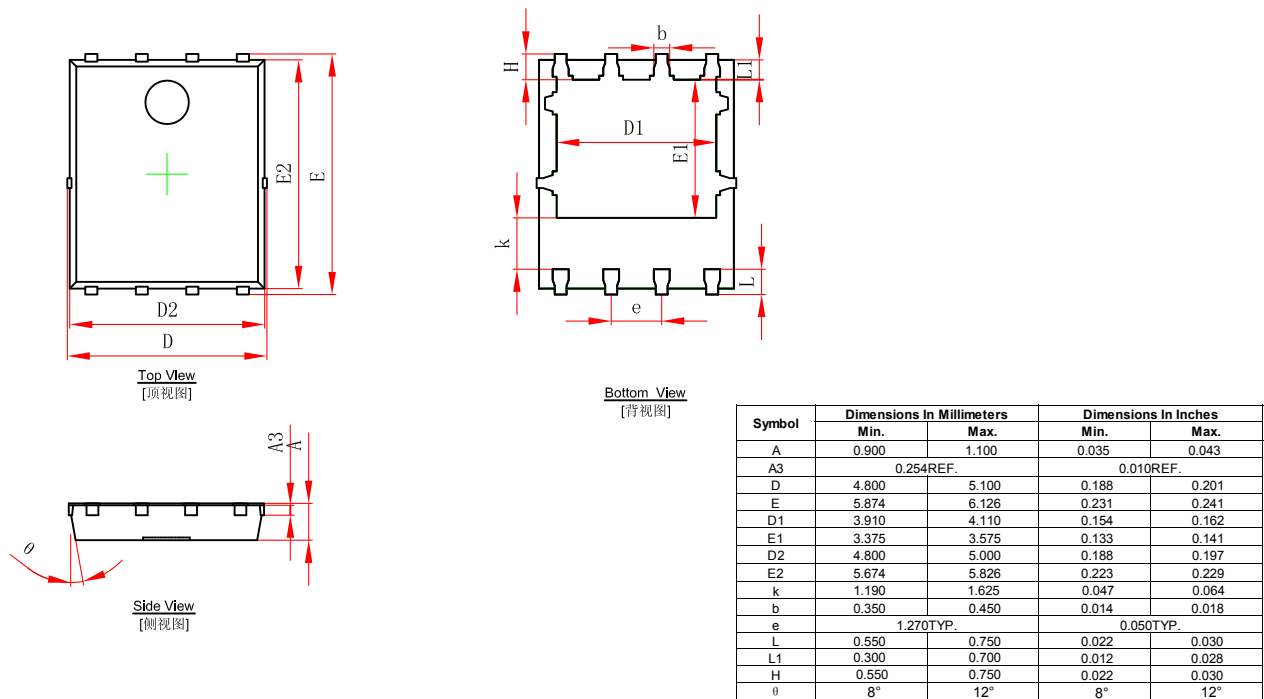

PDFNWB5x6-8L Suggested Pad Layout

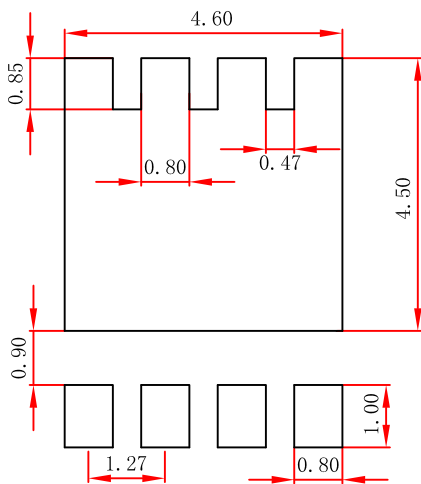

Note:

1. Controlling dimension: in millimeters.
2. General tolerance: ± 0.05 mm.
3. The pad layout is for reference purposes only.

PDFNWB5×6 Tape and Reel

PDFNWB5×6-8L Embossed Carrier Tape

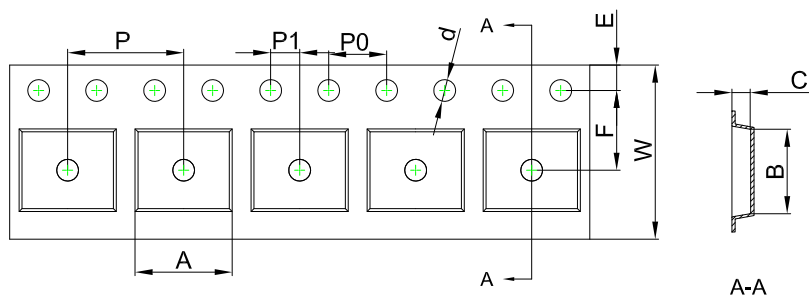

Packaging Description:
PDFNWB5×6-8L parts are shipped in tape. The carrier tape is made from a dissipative (carbon filled) polycarbonate resin. The cover tape is a multilayer film (Heat Activated Adhesive in nature) primarily composed of polyester film, adhesive layer, sealant, and anti-static sprayed agent. These reeled parts in standard option are shipped with 5,000 units per 13" or 33.0 cm diameter reel. The reels are clear in color and is made of polystyrene plastic (anti-static coated).

Dimensions are in millimeter										
Pkg type	A	B	C	d	E	F	P0	P	P1	W
PDFNWB5×6-8L	6.30	5.30	1.10	Ø1.50	1.75	5.50	4.00	8.00	2.00	12.00

PDFNWB5×6-8L Tape Leader and Trailer

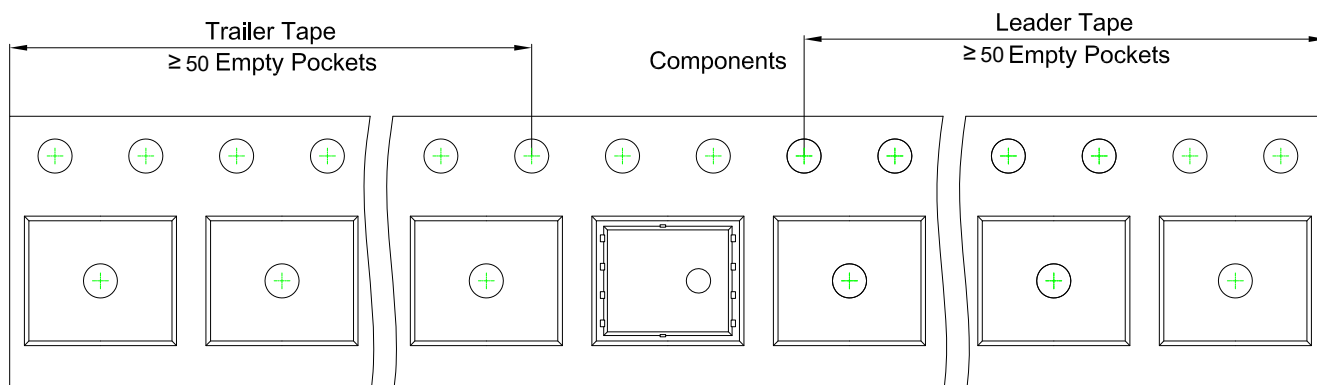

PDFNWB5×6-8L Reel

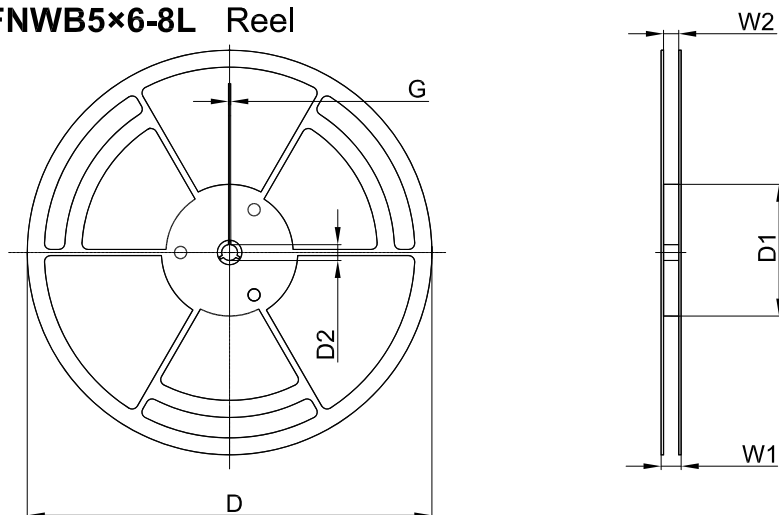

Dimensions are in millimeter						
Reel Option	D	D1	D2	G	W1	W2
13"Dia	Ø330.00	100.00	13.00	1.90	17.60	12.40

REEL	Reel Size	Box	Box Size(mm)	Carton	Carton Size(mm)
5,000 pcs	13 inch	5,000 pcs	340×336×29	50,000 pcs	353×346×365