



WBFBP-02C Plastic-Encapsulate Diodes

DK400LED02 SWITCHING DIODE

DESCRIPTION

Silicon Epitaxial Planar

FEATURES

- Small Surface Mounting Type
- High Speed
- High Reliability with High Surge Current Handling Capability

APPLICATION

High Speed Switching for Detection

For Portable Equipment:(i.e. Mobile Phone,MP3, MD,CD-ROM, DVD-ROM, Note Book PC, etc.)

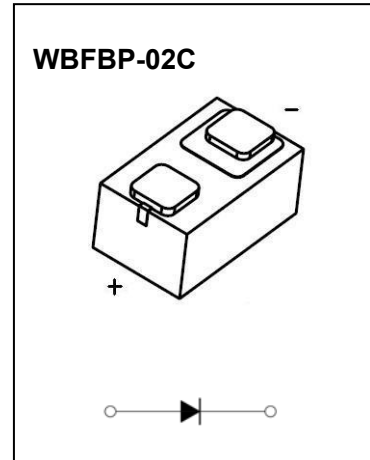

MARKING: 7



Maximum Ratings and Electrical Characteristics, Single Diode @Ta=25°C

Parameter	Symbol	Value	Unit
Peak Reverse Voltage	V_{RM}	90	V
DC Reverse Voltage	V_R	80	V
Peak Forward Current	I_{FM}	300	mA
Average Rectified Output Current	I_o	150	mA
Non-Repetitive Peak Forward Surge Current @t=8.3ms	I_{FSM}	2.0	A
Power dissipation	P_D	100	mW
Thermal resistance From junction to ambient	$R_{\theta JA}$	1250	°C/W
Operation Junction and Storage Temperature Range	T_j, T_{STG}	-55~+150	°C

Electrical Ratings @Ta=25°C

Parameter	Symbol	Min	Typ	Max	Unit	Conditions
Forward voltage	V_F			1.2	V	$I_F=100mA$
Reverse current	I_R			0.1	μA	$V_R=80V$
Capacitance between terminals	C_T			3.0	pF	$V_R=0.5V, f=1MHz$
Reverse recovery time	t_{rr}			4	ns	$V_R=6V, I_F=10mA, R_L=100\Omega$

Typical Characteristics

Forward Characteristics

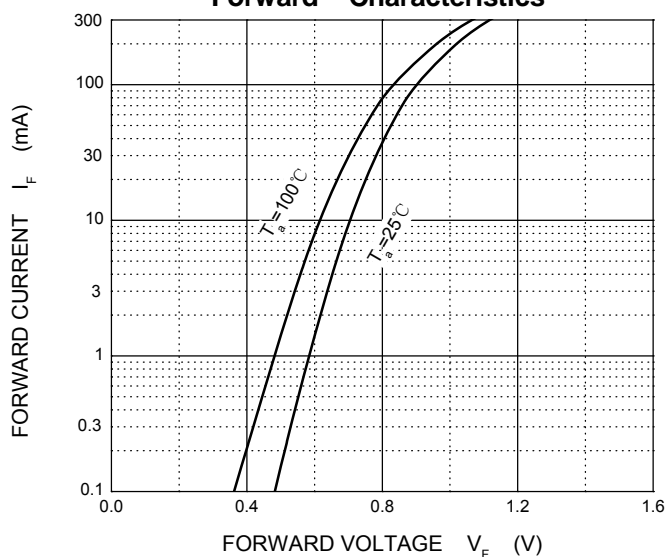

Reverse Characteristics

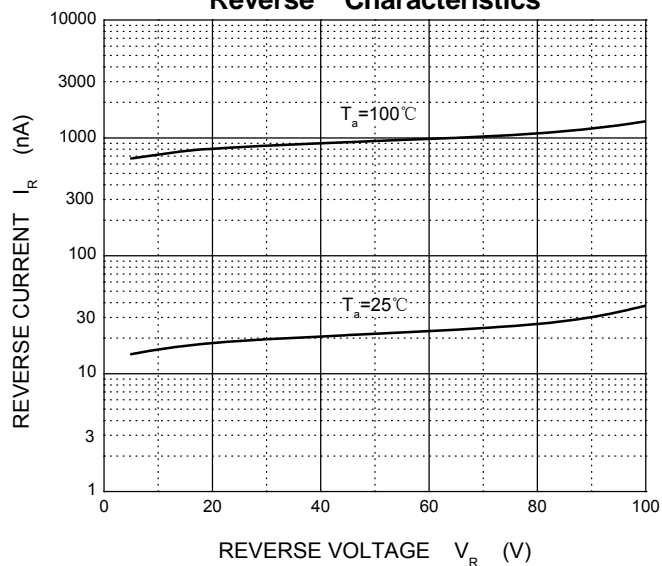

Capacitance Characteristics

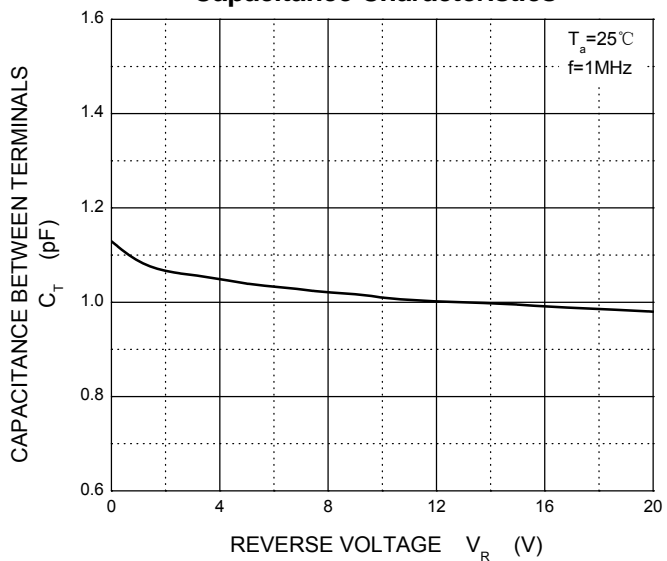

Power Derating Curve

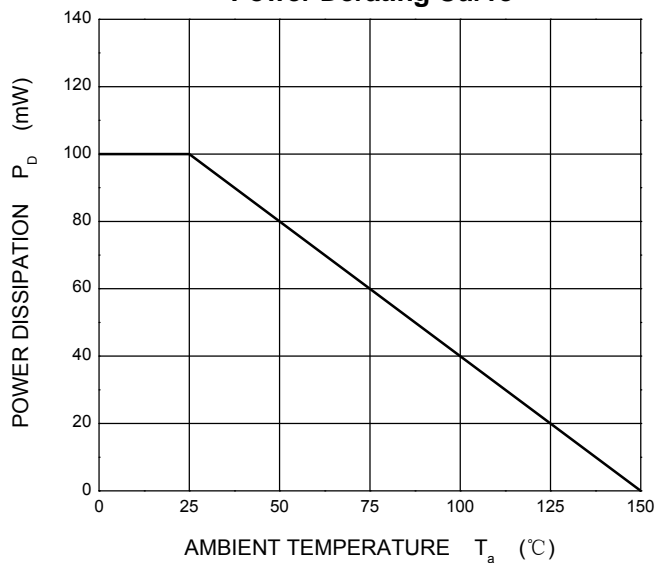

WBFBP-02C Package Outline Dimensions

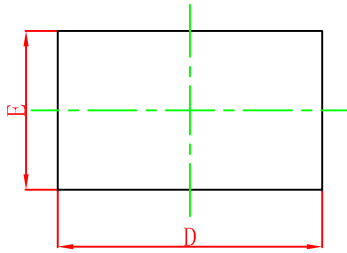

TOP VIEW

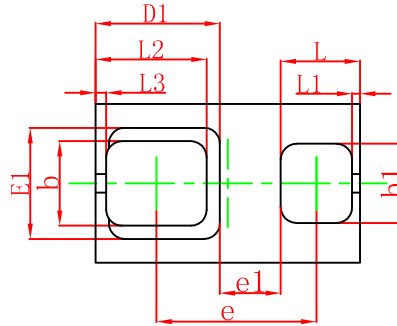

BOTTOM VIEW

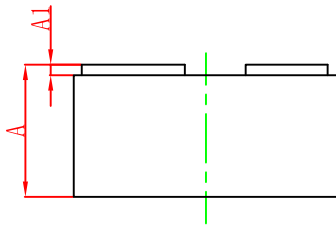

SIDE VIEW

Symbol	Dimensions In Millimeters		Dimensions In Inches	
	Min.	Max.	Min.	Max.
A	0.450	0.550	0.018	0.022
A1	0.010	0.100	0.000	0.004
D	0.950	1.050	0.037	0.041
E	0.550	0.650	0.022	0.026
D1	0.470REF.		0.019REF.	
E1	0.420REF.		0.017REF.	
b	0.270	0.370	0.011	0.015
b1	0.250	0.350	0.010	0.014
e	0.555	0.655	0.022	0.026
e1	0.230REF.		0.009REF.	
L	0.250	0.350	0.010	0.014
L1	0.030REF.		0.001REF.	
L2	0.370	0.470	0.015	0.019
L3	0.040REF.		0.002REF.	

WBFBP-02C Suggested Pad Layout

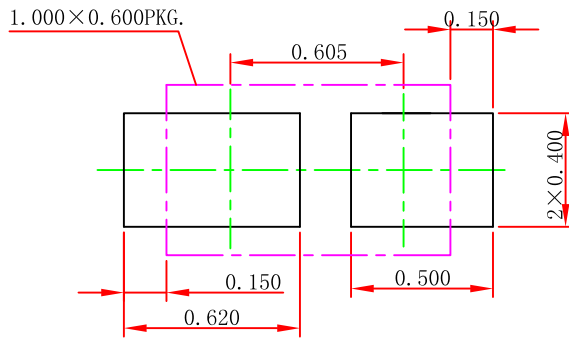

Note:

1. Controlling dimension: in millimeters.
2. General tolerance: ± 0.050 mm.
3. The pad layout is for reference purposes only.

DFN/FBP(1.0X0.6) Tape and Reel

DFN/FBP(1.0×0.6) Embossed Carrier Tape

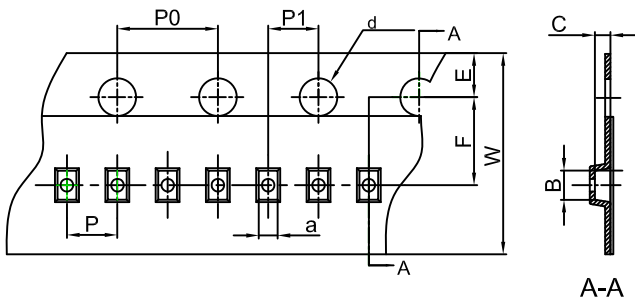

Packaging Description:

DFN/FBP(1.0×0.6) parts are shipped in tape. The carrier tape is made from a dissipative (carbon filled) polycarbonate resin. The cover tape is a multilayer film (Heat Activated Adhesive in nature) primarily composed of polyester film, adhesive layer, sealant, and anti-static sprayed agent. These reeled parts in standard option are shipped with 10,000 units per 7" or 17.8cm diameter reel. The reels are clear in color and is made of polystyrene plastic (anti-static coated).

Dimensions are in millimeter										
Pkg type	a	B	C	d	E	F	P0	P	P1	W
DFN/FBP(1.0×0.6)	0.66	1.15	0.66	Ø1.50	1.75	3.50	4.00	2.00	2.00	8.00

DFN/FBP(1.0×0.6) Tape Leader and Trailer

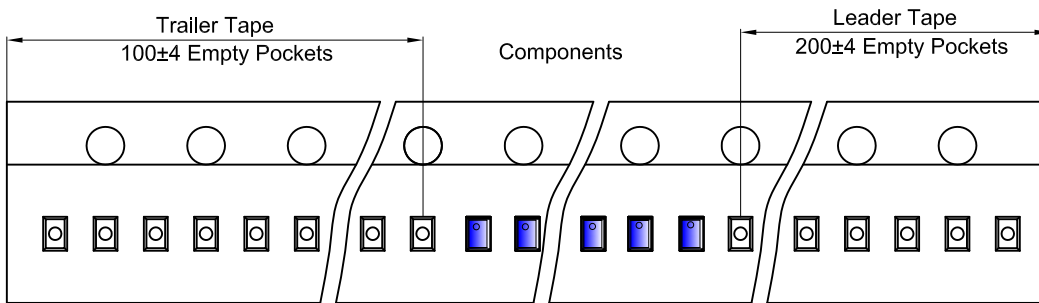

DFN/FBP(1.0×0.6) Reel

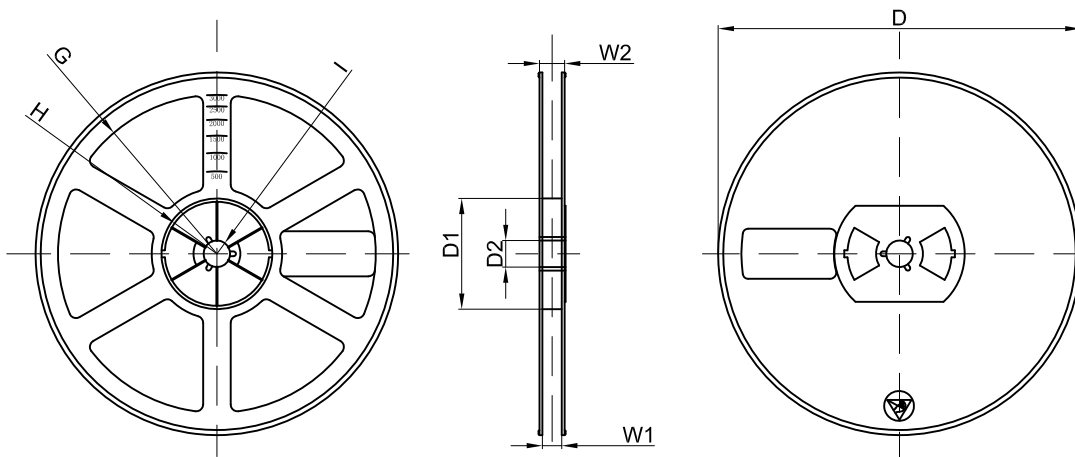

Dimensions are in millimeter								
Reel Option	D	D1	D2	G	H	I	W1	W2
7" Dia	Ø178.00	54.40	13.00	R78.00	R25.60	R6.50	9.50	12.30

REEL	Reel Size	Box	Box Size(mm)	Carton	Carton Size(mm)	G.W.(kg)
10000 pcs	7 inch	150,000 pcs	203×203×195	600,000 pcs	438×438×220	