

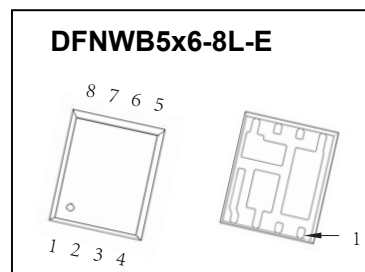

DFNWB5×6-8L-E Plastic-Encapsulate MOSFETS

FB30H20 N-Channel Power MOSFET

$V_{(BR)DSS}$	$R_{DS(on)TYP}$	I_D
30V	8.5mΩ@10V	20A
	12mΩ@4.5V	



DESCRIPTION

The FB30H20 uses advanced trench technology and design to provide excellent $R_{DS(ON)}$ with low gate charge. It can be used in a wide variety of applications

FEATURES

- Full Bridge switch
- Load switch
- High density cell design for ultra low $R_{DS(ON)}$
- Fully characterized avalanche voltage and current
- Good stability and uniformity with high E_{AS}
- Excellent package for good heat dissipation
- Special process technology for high ESD capability

APPLICATIONS

- SMPS and general purpose applications
- Hard switched and high frequency circuits

MARKING

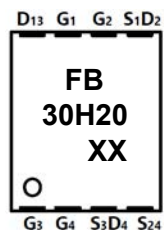

FB30H20 = Part No.
 Solid dot = Pin1 indicator.
 XX = Code.

EQUIVALENT CIRCUIT

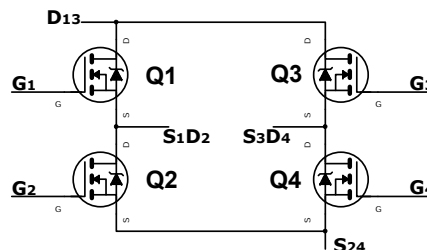

MAXIMUM RATINGS ($T_a=25^{\circ}C$ unless otherwise noted)

Parameter	Symbol	Limit	Unit
Drain-Source Voltage	V_{DS}	30	V
Gate-Source Voltage	V_{GS}	± 20	V
Continuous Drain Current	I_D	20	A
Pulsed Drain Current	I_{DM}	100	A
Single Pulsed Avalanche Energy	$E_{AS}^{(1)}$	70	mJ
Power Dissipation	P_D	1.5	W
Thermal Resistance from Junction to Ambient	$R_{\theta JA}$	83.3	$^{\circ}C/W$
Junction Temperature	T_J	150	$^{\circ}C$
Storage Temperature Range	T_{stg}	-55 ~ +150	$^{\circ}C$
Lead Temperature for Soldering Purposes(1/8" from case for 10s)	T_L	260	$^{\circ}C$

(1).EAS condition: $V_{DD}=15V, L=0.14mH, R_G=25\Omega$, Starting $T_J = 25^{\circ}C$

(2).Mounted on a glass epoxy board of 25.4 mm x 25.4 mm x 0.8 mmt

MOSFET ELECTRICAL CHARACTERISTICS

$T_a=25^\circ\text{C}$ unless otherwise specified

Parameter	Symbol	Test Condition	Min	Typ	Max	Unit
Off characteristics						
Drain-source breakdown voltage	$V_{(BR)DSS}$	$V_{GS} = 0V, I_D = 250\mu A$	30			V
Zero gate voltage drain current	I_{DSS}	$V_{DS} = 30V, V_{GS} = 0V$			1	μA
Gate-body leakage current	I_{GSS}	$V_{DS} = 0V, V_{GS} = \pm 20V$			± 100	nA
On characteristics (note1)						
Gate-threshold voltage	$V_{GS(th)}$	$V_{DS} = V_{GS}, I_D = 250\mu A$	1.0	1.7	3.0	V
Static drain-source on-state resistance	$R_{DS(on)}$	$V_{GS} = 10V, I_D = 10A$		8.5	12	$m\Omega$
		$V_{GS} = 4.5V, I_D = 10A$		12	18	$m\Omega$
Forward transconductance	g_{FS}	$V_{DS} = 5V, I_D = 20A$	15			S
Dynamic characteristics (note 2)						
Input capacitance	C_{iss}	$V_{DS} = 15V, V_{GS} = 0V,$ $f = 1MHz$		823		pF
Output capacitance	C_{oss}			138		
Reverse transfer capacitance	C_{rss}			100		
Switching characteristics (note 2)						
Total gate charge	Q_g	$V_{DS} = 15V, V_{GS} = 10V,$ $I_D = 9A$		13		nC
Gate-source charge	Q_{gs}			3		
Gate-drain charge	Q_{gd}			4.5		
Turn-on delay time	$t_{d(on)}$	$V_{DS} = 15V, V_{GS} = 10V,$ $R_L = 1.8\Omega, R_{GEN} = 3\Omega$			10	ns
Turn-on rise time	t_r				8	
Turn-off delay time	$t_{d(off)}$				30	
Turn-off fall time	t_f				5	
Drain-Source Diode Characteristics						
Drain-source diode forward voltage(note1)	V_{SD}	$V_{GS} = 0V, I_S = 10A$			1.2	V
Continuous drain-source diode forward current	I_S				20	A
Pulsed drain-source diode forward current	I_{SM}				100	A
Reverse Recovery Time	t_{rr}	$T_J = 25^\circ\text{C}, I_F = 10A$		22	35	ns
Reverse Recovery Charge	Q_{rr}	$di/dt = 100A/\mu s(\text{Note1})$		12	20	nC

Notes:

1. Pulse Test : Pulse Width $\leq 300\mu s$, duty cycle $\leq 2\%$.
2. Guaranteed by design, not subject to production.

Typical Characteristics

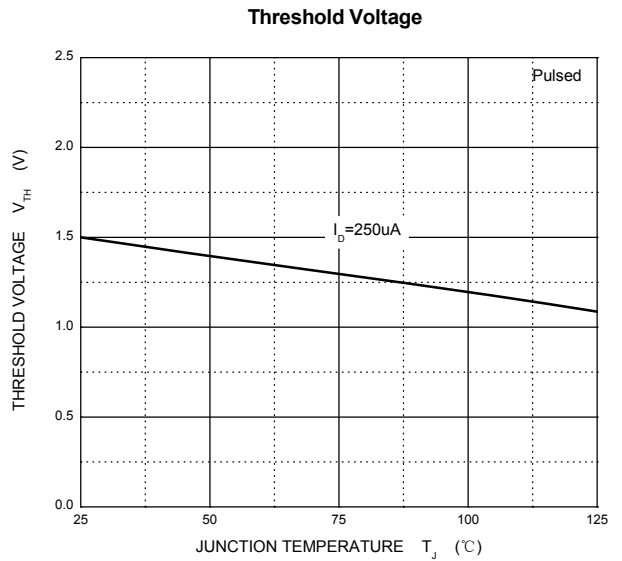
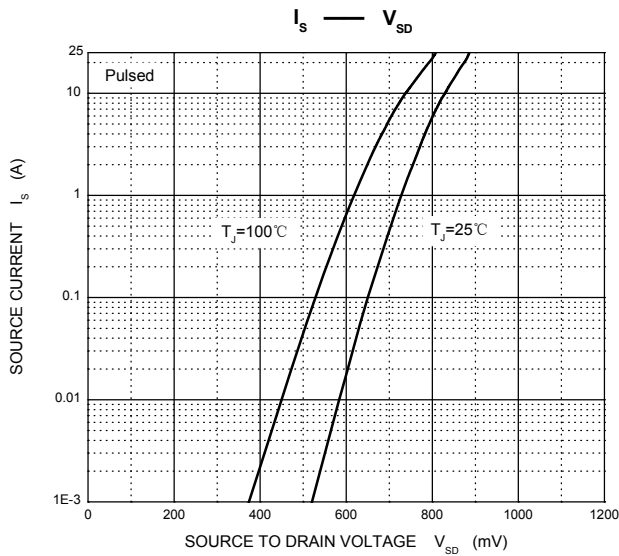
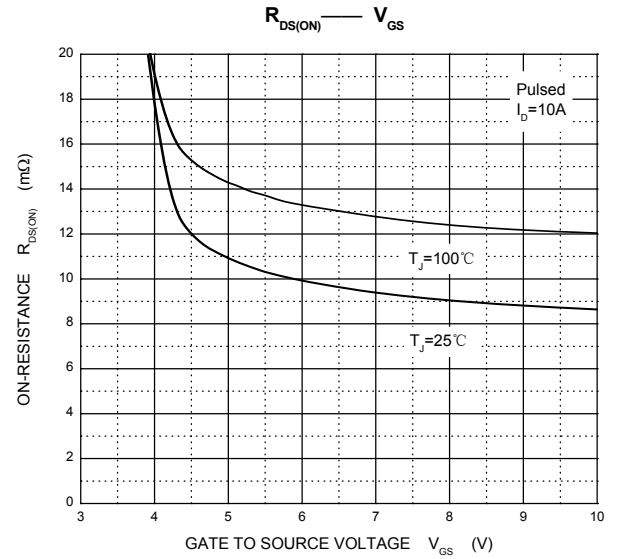
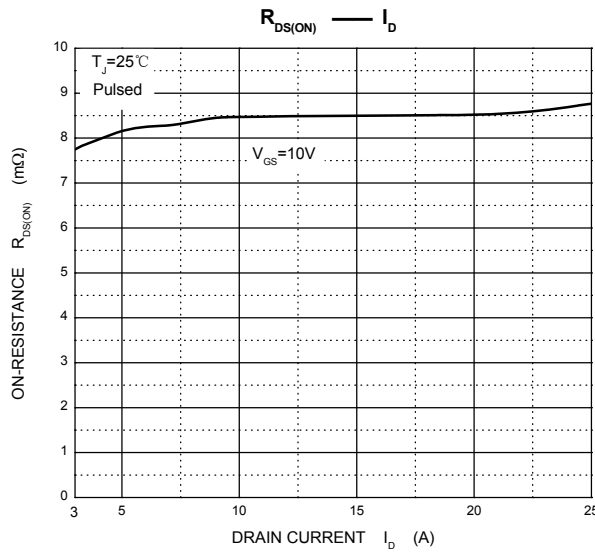
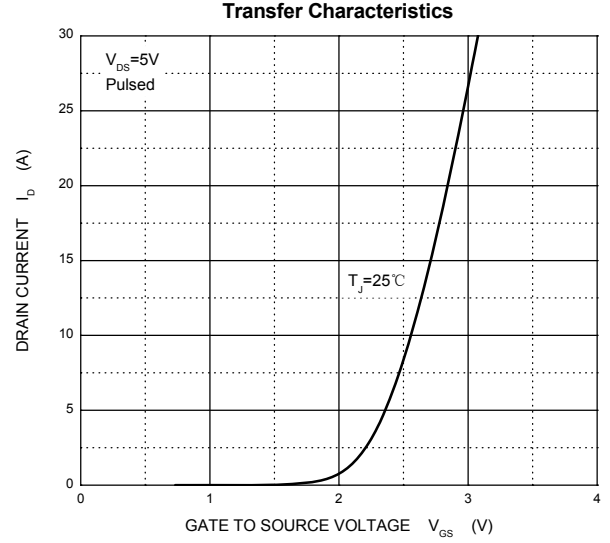
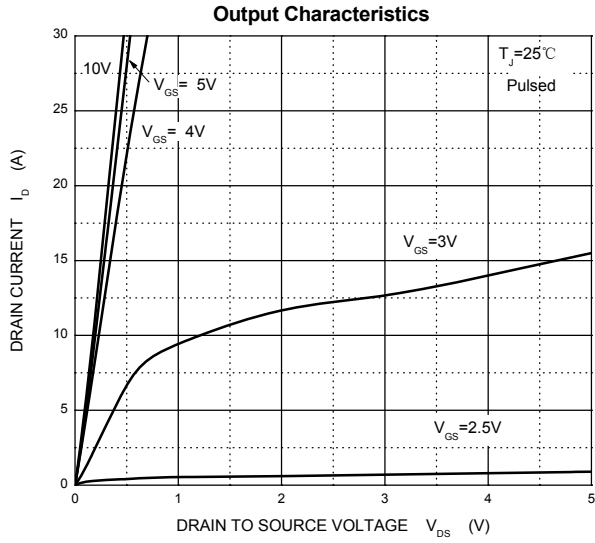

DFNWB5×6-8L-E Package Outline Dimensions

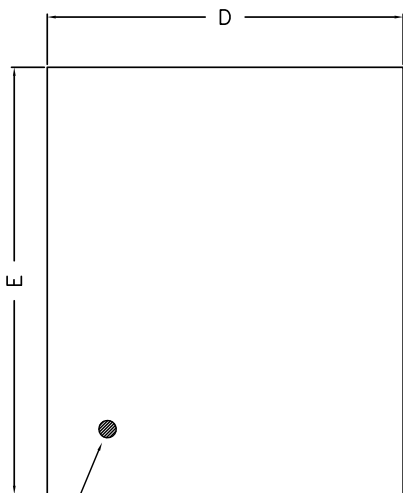

PIN 1 DOT BY MARKING

Top View
[顶视图]

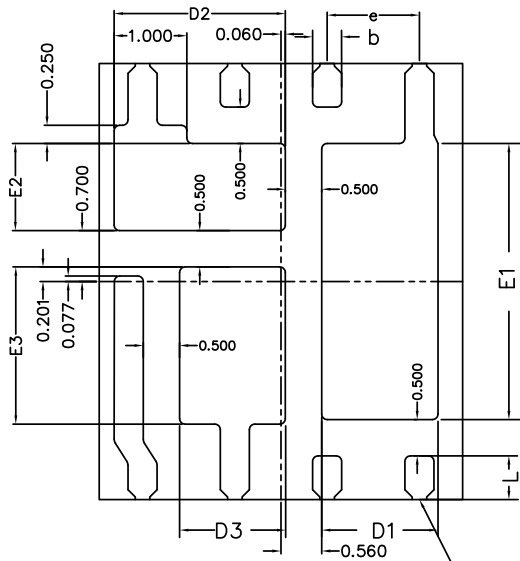

Bottom View
[背视图]

PIN #1 LOCATION

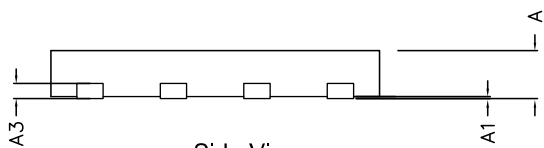

Side View
[侧视图]

COMMON DIMENSIONS(MM)			
PKG.	W:VERY VERY THIN		
REF.	MIN.	NOM.	MAX
A	0.70	0.75	0.80
A1	0.00	-	0.05
A3	0.2 REF.		
D	4.90	5.00	5.10
E	5.90	6.00	6.10
b	0.35	0.40	0.45
L	0.50	0.60	0.70
D1	1.35	1.60	1.70
E1	3.65	3.80	3.90
D2	2.205	2.355	2.455
E2	1.05	1.20	1.30
D3	1.305	1.455	1.555
E3	2.013	2.163	2.263
e	1.27 BSC		

DFNWB5x6-8L-E Tape and Reel

DFNWB5x6-8L-E Embossed Carrier Tape

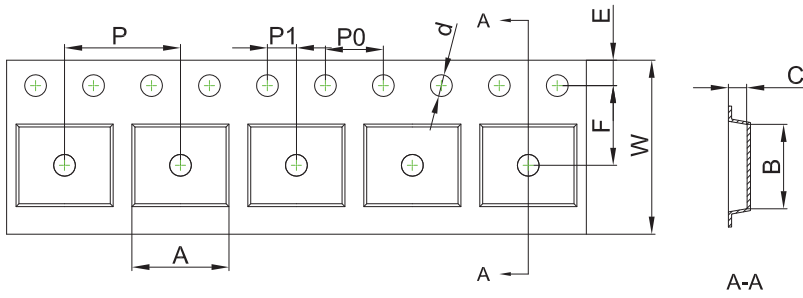

Packaging Description:
DFNWB5x6-8L-E parts are shipped in tape. The carrier tape is made from a dissipative (carbon filled) polycarbonate resin. The cover tape is a multilayer film (Heat Activated Adhesive in nature) primarily composed of polyester film, adhesive layer, sealant, and anti-static sprayed agent. These reeled parts in standard option are shipped with 5,000 units per 13" or 33.0 cm diameter reel. The reels are clear in color and is made of polystyrene plastic (anti-static coated).

Dimensions are in millimeter										
Pkg type	A	B	C	d	E	F	P0	P	P1	W
DFNWB5x6-8L-E	6.30	5.30	1.10	Ø1.50	1.75	5.50	4.00	8.00	2.00	12.00

DFNWB5x6-8L-E Tape Leader and Trailer

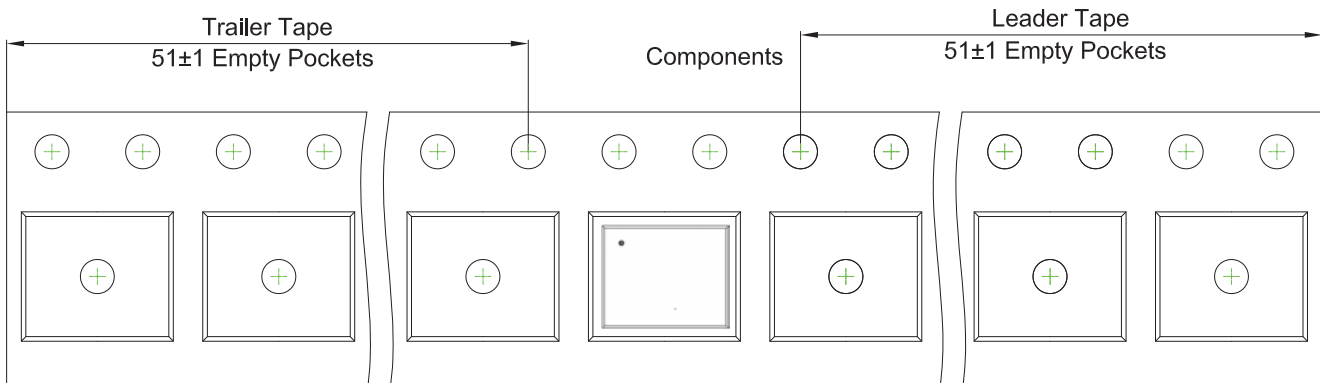

DFNWB5x6-8L-E Reel

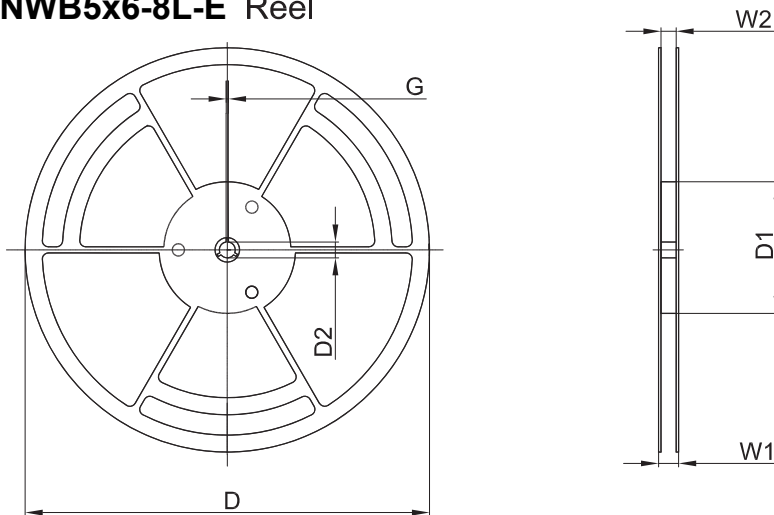

Dimensions are in millimeter						
Reel Option	D	D1	D2	G	W1	W2
13" Dia	Ø330.00	100.00	13.00	1.90	17.60	12.40

REEL	Reel Size	Box	Box Size(mm)	Carton	Carton Size(mm)
5,000 pcs	13 inch	5,000 pcs	340×336×29	50,000 pcs	353×346×365