



TO-251-3L Plastic-Encapsulate Transistors

MJD112 TRANSISTOR (NPN)

FEATURES

- Complementary Darlington Power Transistors
- Dpak for Surface Mount Applications

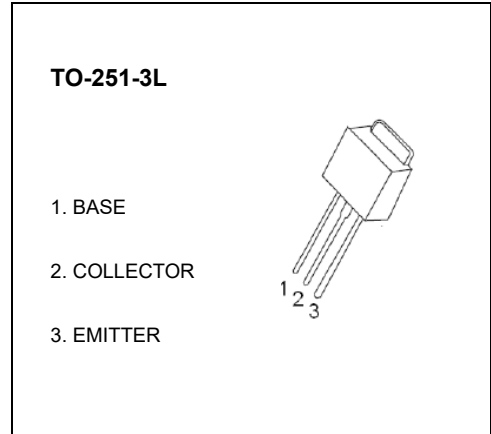

MARKING

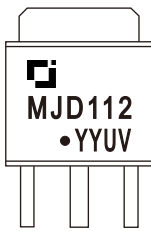

MJD112=Device code
Solid dot=Green moldinn compound device,
if none,the normal device
XXXX=Code

Equivalent Circuit

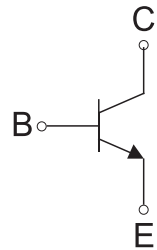

MAXIMUM RATINGS ($T_a=25^{\circ}\text{C}$ unless otherwise noted)

Symbol	Parameter	Value	Unit
V_{CB0}	Collector-Base Voltage	100	V
V_{CE0}	Collector-Emitter Voltage	100	V
V_{EB0}	Emitter-Base Voltage	5	V
I_C	Collector Current -Continuous	2	A
P_C	Collector Power Dissipation	1.5	W
$R_{\theta JC}$	Thermal resistance, junction to case	6.25	$^{\circ}\text{C}/\text{W}$
$R_{\theta JA}$	Thermal resistance, junction to Ambient	83.3	$^{\circ}\text{C}/\text{W}$
T_J, T_{stg}	Operation Junction and Storage Temperature Range	-55-150	$^{\circ}\text{C}$

ELECTRICAL CHARACTERISTICS (T_a=25°C unless otherwise specified)

Parameter	Symbol	Test conditions	Min	Typ	Max	U
Collector-base breakdown voltage	V _{(BR)CBO}	I _C =1mA, I _E =0	100			V
Collector-emitter breakdown voltage	V _{(BR)CEO}	I _C =30mA, I _B =0	100			V
Emitter-base breakdown voltage	V _{(BR)EBO}	I _E =5mA, I _C =0	5			V
Collector cut-off current	I _{CBO}	V _{CB} =100V, I _E =0			20	μA
Collector-emitter cut-off current	I _{CEO}	V _{CE} =50V, I _E =0			20	μA
Emitter cut-off current	I _{EBO}	V _{EB} =5V, I _C =0			2	mA
DC current gain	h _{FE(1)}	V _{CE} =3V, I _C =500mA	500			
	h _{FE(2)}	V _{CE} =3V, I _C =2A	1000		12000	
	h _{FE(3)}	V _{CE} =3V, I _C =4A	200			
Collector-emitter saturation voltage	V _{CE(sat)1}	I _C =2A, I _B =8mA			2	V
	V _{CE(sat)2}	I _C =4A, I _B =40mA			3	V
Base-emitter voltage	V _{BE}	V _{CE} =3V, I _C =2A			2.8	V
Transition frequency	f _T	V _{CE} =10V, I _C =0.75A, f=1MHz	25			MHz
Collector output capacitance	C _{ob}	V _{CB} =10V, I _E =0, f=0.1MHz			100	pF

Typical Characteristics

MJD112

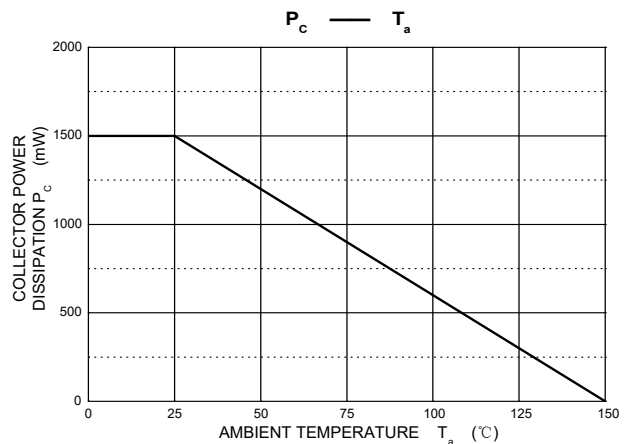
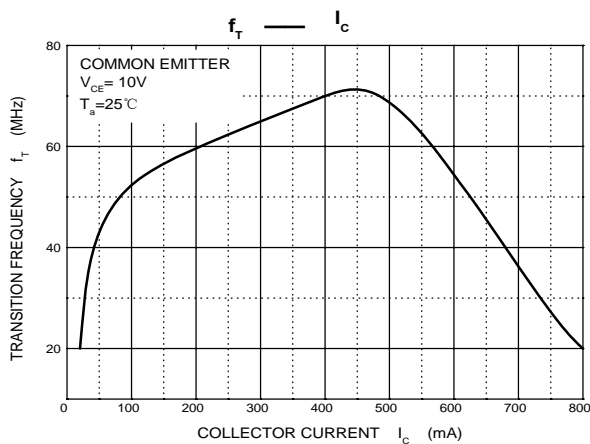
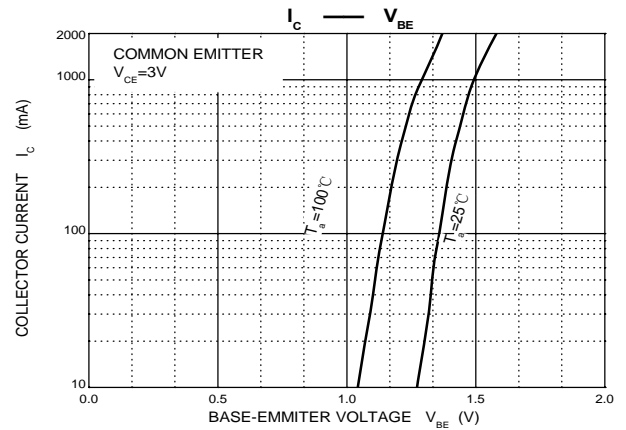
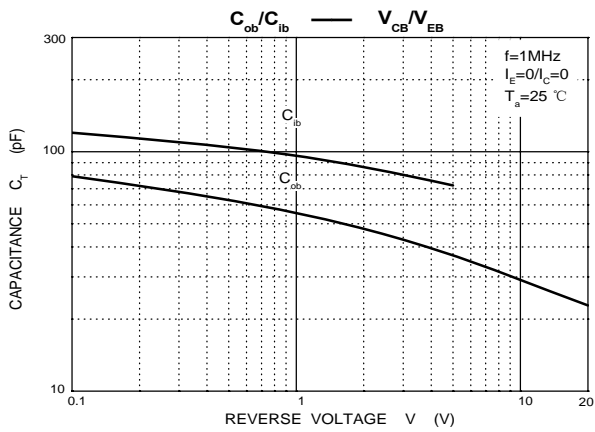
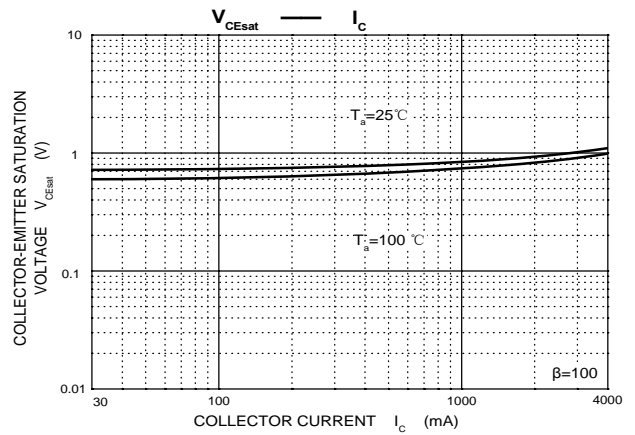
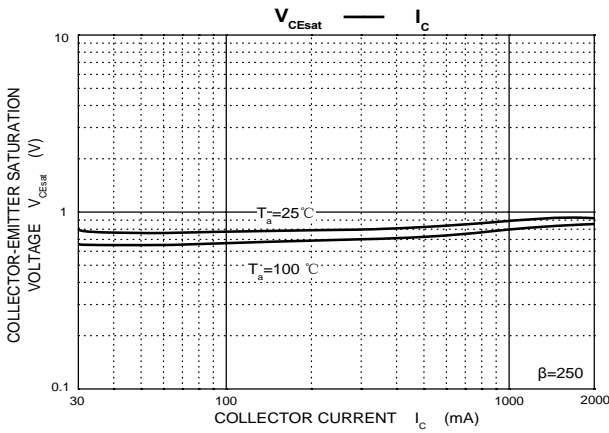
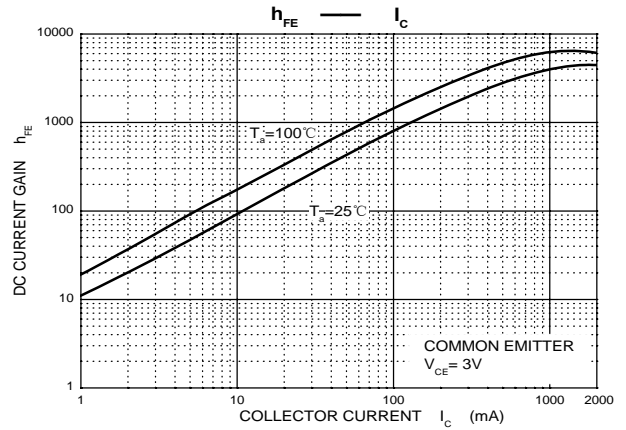
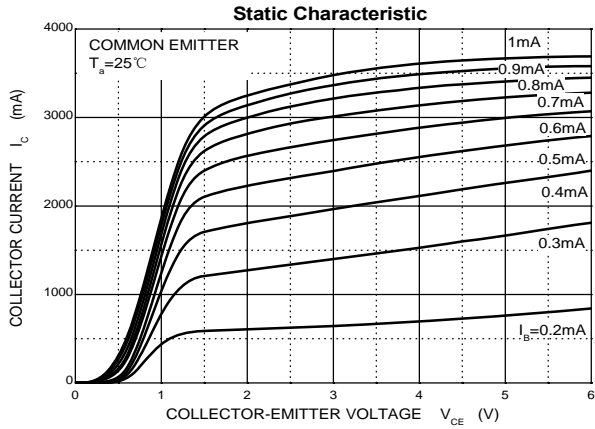

TO-251-3L Package Outline Dimensions

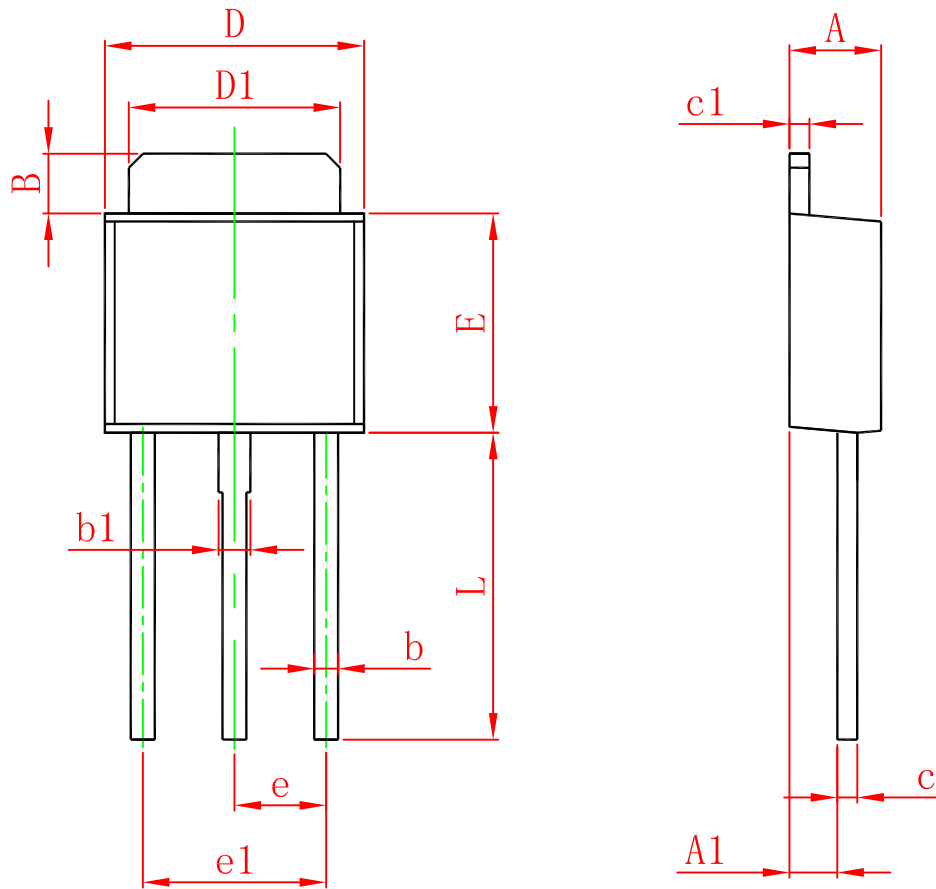

Symbol	Dimensions In Millimeters		Dimensions In Inches	
	Min.	Max.	Min.	Max.
A	2.200	2.400	0.087	0.094
A1	1.050	1.350	0.042	0.054
B	1.350	1.650	0.053	0.065
b	0.500	0.700	0.020	0.028
b1	0.700	0.900	0.028	0.035
c	0.430	0.580	0.017	0.023
c1	0.430	0.580	0.017	0.023
D	6.350	6.650	0.250	0.262
D1	5.200	5.400	0.205	0.213
E	5.400	5.700	0.213	0.224
e	2.300 TYP.		0.091 TYP.	
e1	4.500	4.700	0.177	0.185
L	7.500	7.900	0.295	0.311