

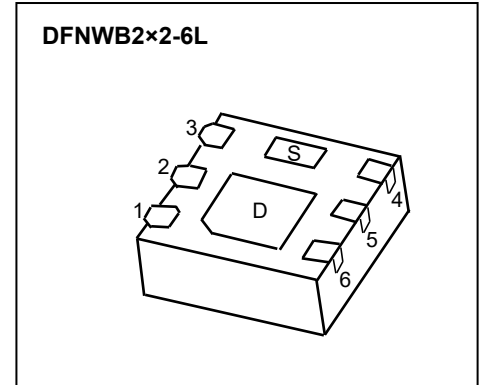

DFNWB2×2-6L Plastic-Encapsulate MOSFETS

MN3010 N-Channel MOSFET

$V_{(BR)DSS}$	$R_{DS(on)TYP}$	I_D
30V	12.8mΩ@ 4.5V	10A
	9.4mΩ@ 10V	



FEATURES

- TrenchFET Power MOSFET
- Small package DFNWB2×2-6L

APPLICATION

- Load Switch for Portable Applications

MARKING:

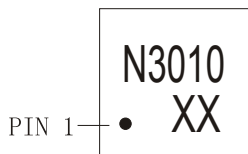

N3010 = Part No.
 Solid dot = Pin1 indicator.
 XX = Code.

Equivalent Circuit

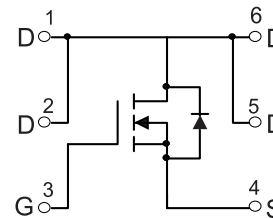

ABSOLUTE MAXIMUM RATINGS ($T_a=25^\circ\text{C}$ unless otherwise noted)

Parameter	Symbol	Value	Unit
Drain-Source Voltage	V_{DS}	30	V
Drain Current (Continuous)	I_D	10	A
Drain Current (Pulse)	I_{DM}	40	A
Gate-Source Voltage	V_{GS}	±20	V
Static Drain-Source On-Resistance	$R_{DS(on)}$	2.5	mΩ
Storage Temperature Range	$T_{J, T_{stg}}$	50	$^\circ\text{C}$
Operating Junction and Storage Temperature Range	T_J, T_{stg}	-55~+150	$^\circ\text{C}$

MOSFET ELECTRICAL CHARACTERISTICS

$T_a=25^\circ\text{C}$ unless otherwise specified

Parameter	Symbol	Test Condition	Min	Typ	Max	Unit
STATIC PARAMETERS ^④						
Drain-source breakdown voltage	$V_{(BR)DSS}$	$V_{GS} = 0V, I_D = 250\mu A$	30			V
Zero gate voltage drain current	I_{DSS}	$V_{DS} = 24V, V_{GS} = 0V$	$T_J = 25^\circ\text{C}$		1.0	μA
			$T_J = 125^\circ\text{C}$		100	
Gate-body leakage current	I_{GSS}	$V_{GS} = \pm 20V, V_{DS} = 0V$			± 100	nA
Gate threshold voltage	$V_{GS(th)}$	$V_{DS} = V_{GS}, I_D = 250\mu A$	1.0	1.6	2.5	V
Drain-source on-resistance	$R_{DS(on)}$	$V_{GS} = 10V, I_D = 5A$	6.0	9.4	12	m Ω
		$V_{GS} = 4.5V, I_D = 5A$	10	12.8	16	m Ω
DYNAMIC PARAMETERS ^{④ ⑤}						
Input Capacitance	C_{iss}	$V_{DS} = 15V, V_{GS} = 0V, f = 1\text{MHz}$	800	1338	2650	pF
Output Capacitance	C_{oss}		100	155	320	pF
Reverse Transfer Capacitance	C_{rss}		90	145	290	pF
Gate Resistance	R_g	$f = 1\text{MHz}$		4.6		Ω
SWITCHING PARAMETERS ^{④ ⑤}						
Turn-on delay time	$t_{d(on)}$	$V_{DD} = 15V, V_{GS} = 10V, I_D = 1A, R_{GEN} = 3\Omega$		7.0		ns
Turn-on rise time	t_r			14		ns
Turn-off delay time	$t_{d(off)}$			20		ns
Turn-off fall time	t_f			6.0		ns
Total Gate Charge	Q_g	$V_{DS} = 15V, V_{GS} = 5V, I_D = 10A$		12.5	25	nC
Gate-Source Charge	Q_{gs}			5.0	10	nC
Gate-Drain Charge	Q_{gd}			3.0	6.0	nC
Drain-Source Diode Characteristics						
Drain-source diode forward voltage	V_{SD} ^④	$V_{GS} = 0V, I_S = 1A$			1.0	V
Continuous drain-source diode forward current	I_S ^①				10	A
Pulsed drain-source diode forward current	I_{SM} ^②				40	A

Notes:

1. $T_C = 25^\circ\text{C}$ Limited only by maximum temperature allowed.

2. $P_W \leq 10\mu s$, Duty cycle $\leq 1\%$.

3. EAS condition: $V_{DD} = 20V, V_{GS} = 10V, L = 0.5\text{mH}, R_g = 25\Omega$ Starting $T_J = 25^\circ\text{C}$.

4. Pulse Test : Pulse Width $\leq 300\mu s$, duty cycle $\leq 2\%$.

5. Guaranteed by design, not subject to production.

6. The value of $R_{\theta JA}, R_{\theta JC}$ is measured with the device mounted on 1 in 2 FR-4 board with 2oz. Copper, in a still air environment with $T_a = 25^\circ\text{C}$.

Typical Characteristics

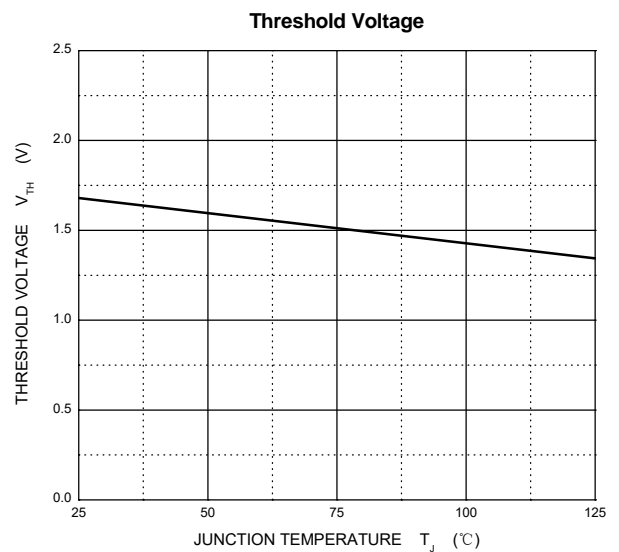
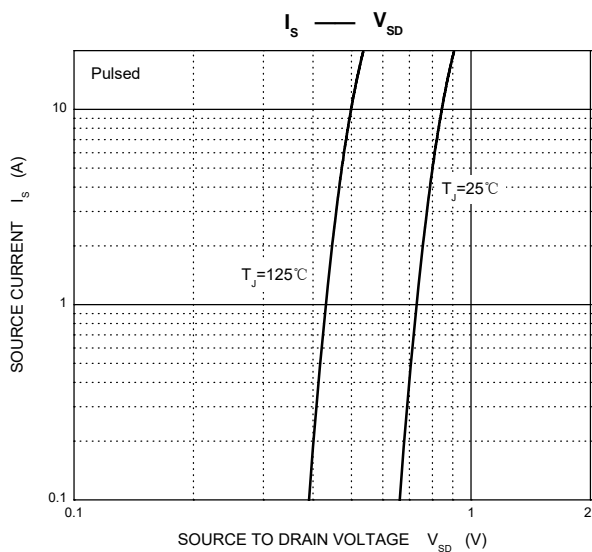
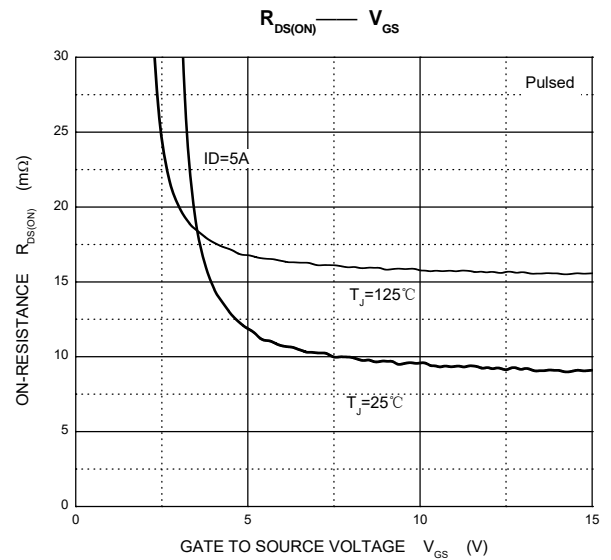
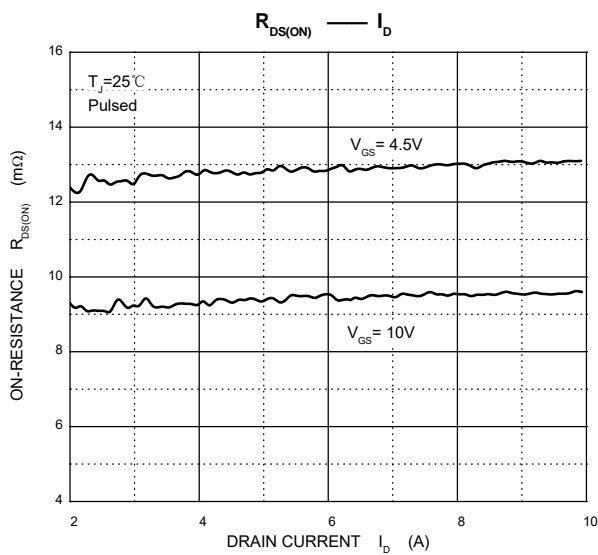
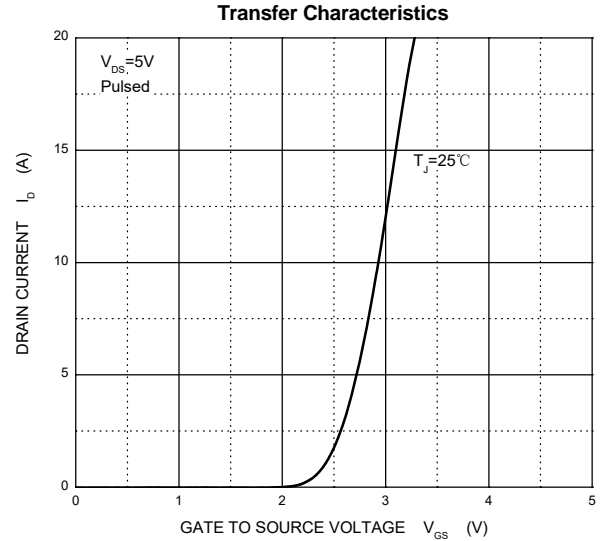
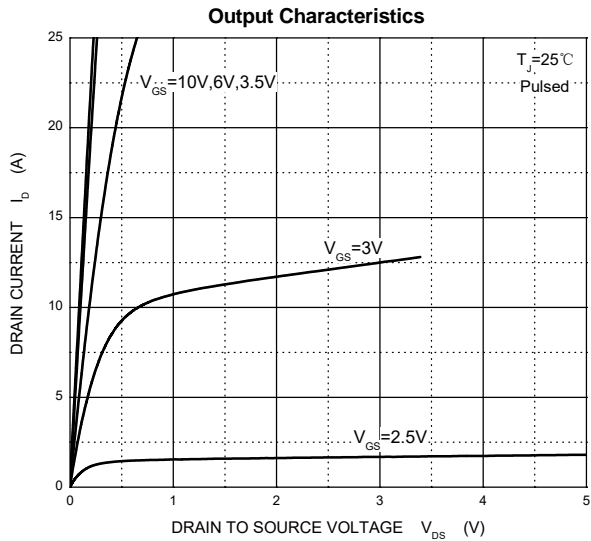

Typical Characteristics

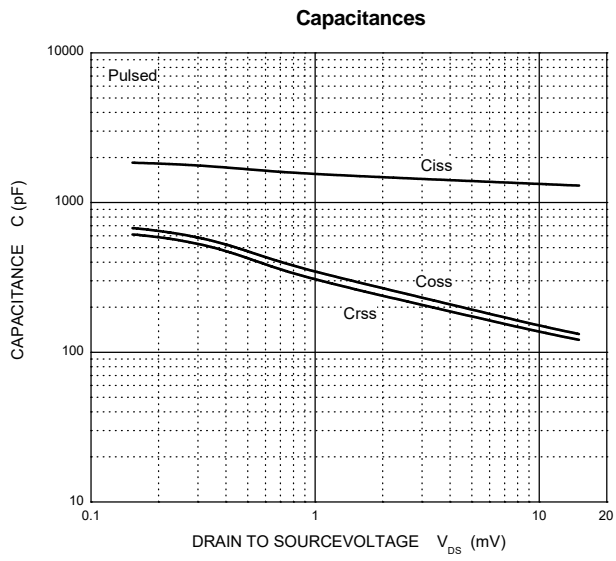

DFNWB2×2-6L-J Package Outline Dimensions

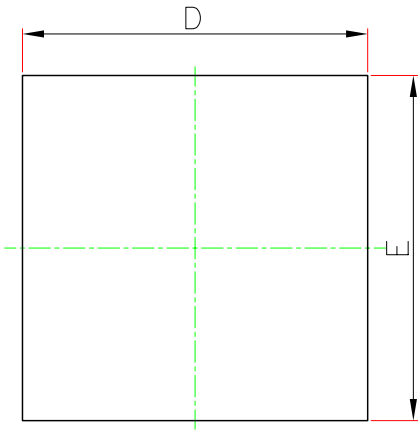

TOP VIEW
[顶视图]

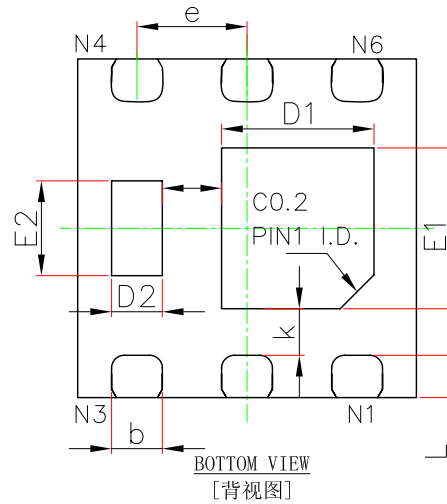

BOTTOM VIEW
[背视图]

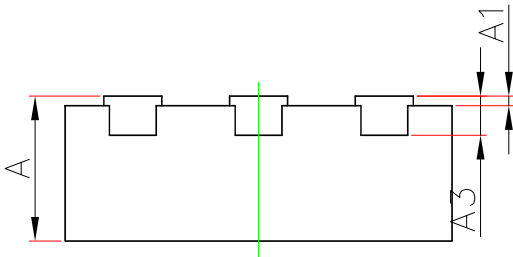

SIDE VIEW
[侧视图]

Symbols	Dimensions in Millimeters		Dimensions in Inches	
	Min.	Max.	Min.	Max.
A	0.700	0.800	0.028	0.031
A1	0.000	0.050	0.000	0.002
A3	0.203REF.		0.008REF.	
D	1.900	2.100	0.075	0.083
E	1.900	2.100	0.075	0.083
D1	0.800	1.000	0.031	0.039
E1	0.850	1.050	0.033	0.041
D2	0.200	0.400	0.008	0.016
E2	0.460	0.660	0.018	0.026
b	0.250	0.350	0.010	0.014
e	0.650BSC.		0.026BSC.	
k	0.275REF.		0.011REF.	
k1	0.350REF.		0.014REF.	
L	0.174	0.326	0.007	0.013

DFNWB2×2-6L-J Suggested Pad Layout

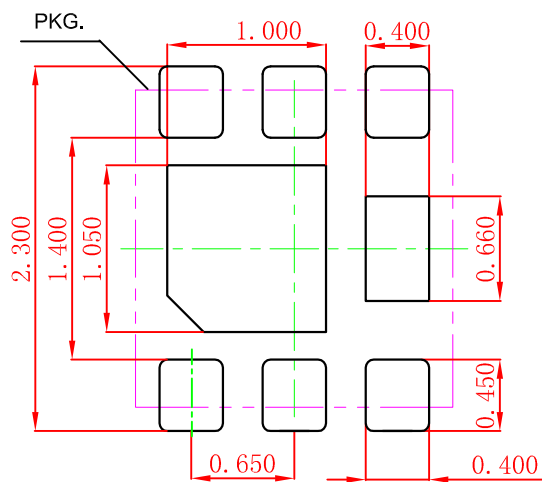

Note:

1. Controlling dimension: in millimeters.
2. General tolerance: $\pm 0.050\text{mm}$.
3. The pad layout is for reference purposes only.

DFNWB2X2-6L Tape and Reel

DFNWB2×2-6L Embossed Carrier Tape

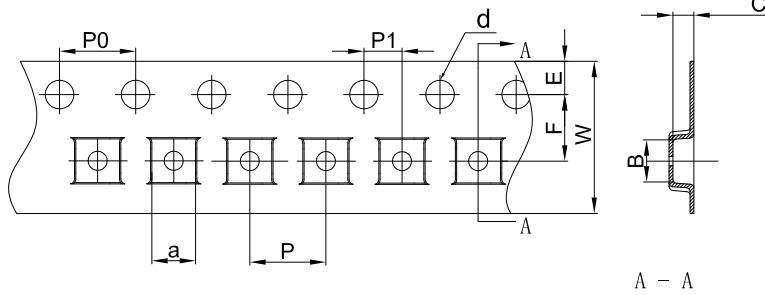

Packaging Description:

DFNWB2×2-6L parts are shipped in tape. The carrier tape is made from a dissipative (carbon filled) polycarbonate resin. The cover tape is a multilayer film (Heat Activated Adhesive in nature) primarily composed of polyester film, adhesive layer, sealant, and anti-static sprayed agent. These reeled parts in standard option are shipped with 3,000 units per 7" or 18.0cm diameter reel. The reels are clear in color and is made of polystyrene plastic (anti-static coated).

Dimensions are in millimeter

Pkg type	a	B	C	d	E	F	P0	P	P1	W
DFNWB2×2-6L	2.30	2.30	1.10	Ø1.50	1.75	3.50	4.00	4.00	2.00	8.00

DFNWB2×2-6L Tape Leader and Trailer

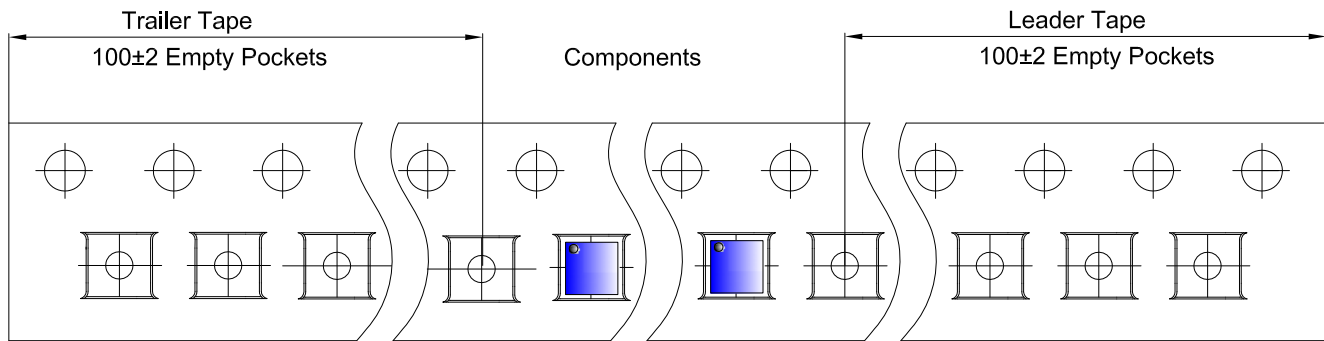

DFNWB2×2-6L Reel

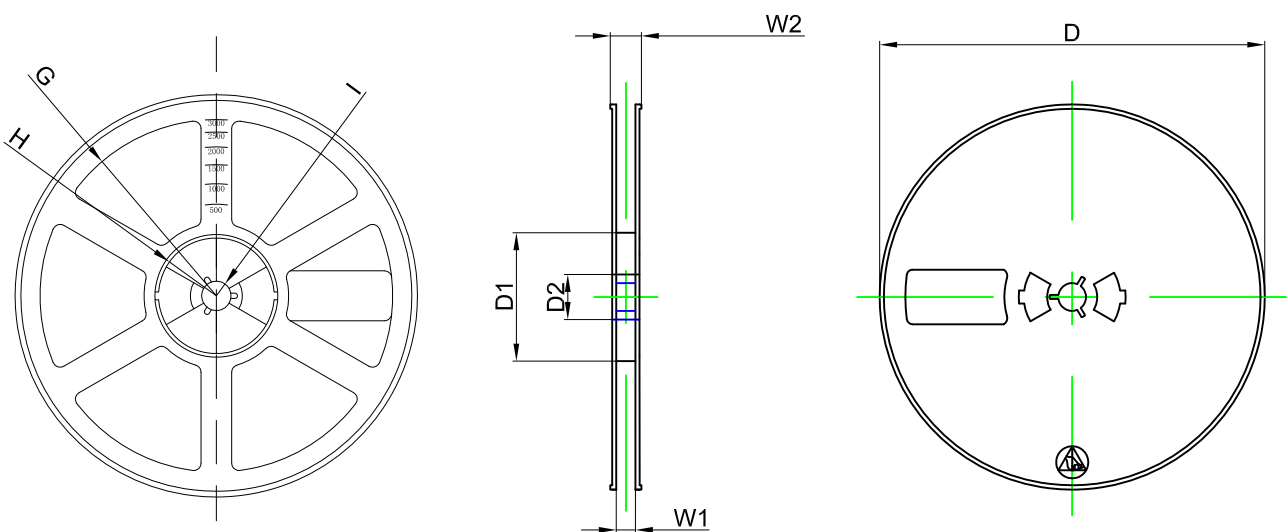

Dimensions are in millimeter

Reel Option	D	D1	D2	G	H	I	W1	W2
7" Dia	Ø180.00	60.00	13.00	R78.00	R25.60	R6.50	9.50	13.10

REEL	Reel Size	Box	Box Size(mm)	Carton	Carton Size(mm)	G.W.(kg)
3000 pcs	7 inch	30,000 pcs	203×203×195	120,000 pcs	438×438×220	