



# SMBF Plastic-Encapsulate Diodes

## RS2ABF THRU RS2MBF Fast Recovery Rectifier Diodes

### Features

- $I_{F(AV)}$  2A
- $V_{RRM}$  50V-1000V
- High surge current capability
- Polarity: Color band denotes cathode

### Applications

- Rectifier

### Marking

- RS2XBF
- X : From A To M

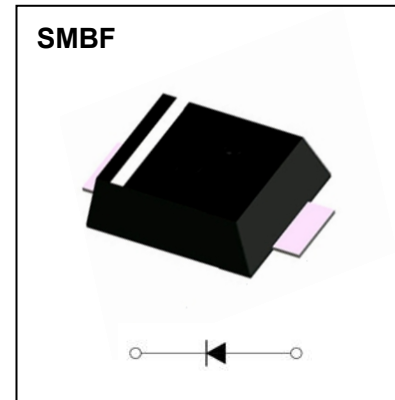

### Limiting Values(Absolute Maximum Rating)

Item	Symbol	Unit	Test Conditions	RS2						
				ABF	BBF	DBF	GBF	JBF	KBF	MBF
Repetitive Peak Reverse Voltage	$V_{RRM}$	V		50	100	200	400	600	800	1000
Maximum RMS Voltage	$V_{RMS}$	V		35	70	140	280	420	560	700
Average Forward Current	$I_{F(AV)}$	A	60Hz Half-sine wave, Resistance load, $T_L=100\text{ }^\circ\text{C}$	2.0						
Surge(Non-repetitive)Forward Current	$I_{FSM}$	A	60Hz Half-sine wave, 1 cycle, $T_a=25\text{ }^\circ\text{C}$	60						
Junction Temperature	$T_J$	$^\circ\text{C}$		-55 ~ +150						
Storage Temperature	$T_{STG}$	$^\circ\text{C}$		-55 ~ +150						

### Electrical Characteristics (T=25°C Unless otherwise specified)

Item	Symbol	Unit	Test Condition	RS2						
				ABF	BBF	DBF	GBF	JBF	KBF	MBF
Peak Forward Voltage	$V_F$	V	$I_F=2.0\text{A}$	1.3						
Peak Reverse Current	$I_{RRM1}$	$\mu\text{A}$	$V_{RM}=V_{RRM}$	$T_a=25\text{ }^\circ\text{C}$						
	$I_{RRM2}$			$T_a=125\text{ }^\circ\text{C}$						
Thermal Resistance(Typical)	$R_{\theta J-A}$	$^\circ\text{C}/\text{W}$	Between junction and ambient	78						
Typical junction capacitance per diode	$C_J$	pF	Measured at 1.0MHz and applied reverse voltage of 4.0 volts.	60						
Maximum reverse recovery time	$t_{rr}$	ns	$I_F=0.5\text{A}, I_R=1.0\text{A}, I_{tr}=0.25\text{A}$	150			250		500	

# Typical Characteristics

FIG.1: FORWARD CURRENT DERATING CURVE

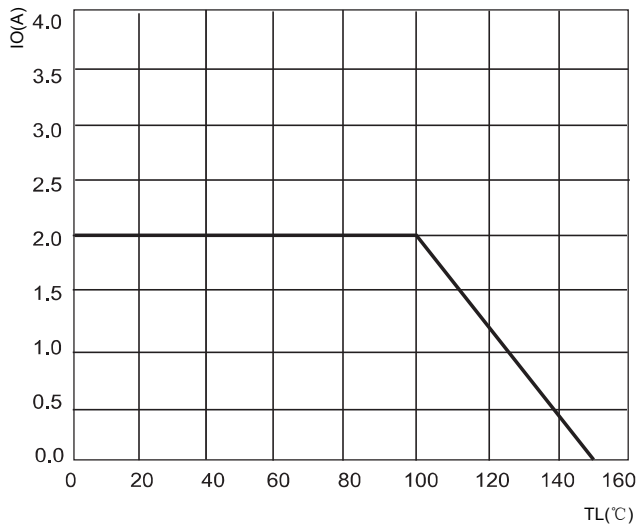

FIG2: Surge Forward Current Capacity

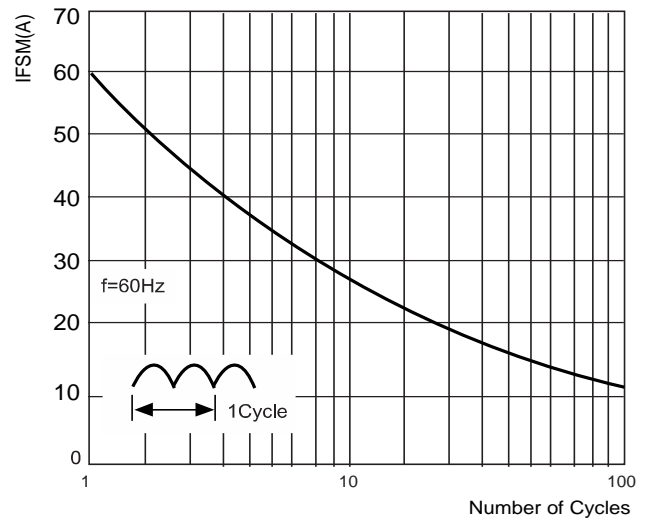

FIG.3: TYPICAL FORWARD CHARACTERISTICS

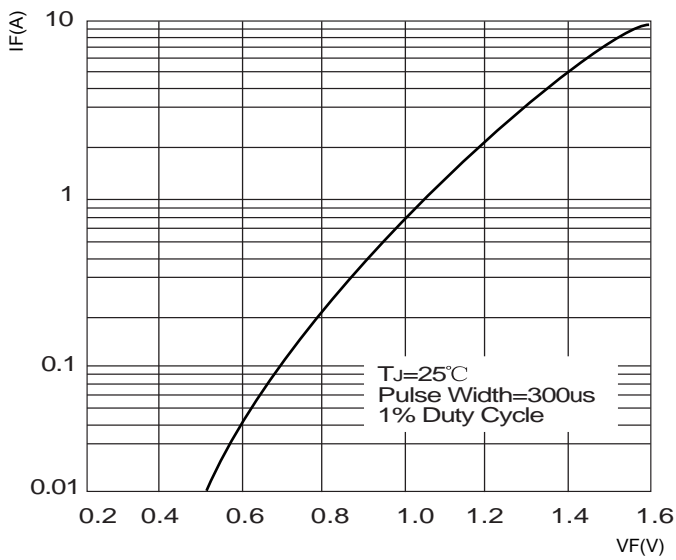

FIG.4 : TYPICAL REVERSE CHARACTERISTICS

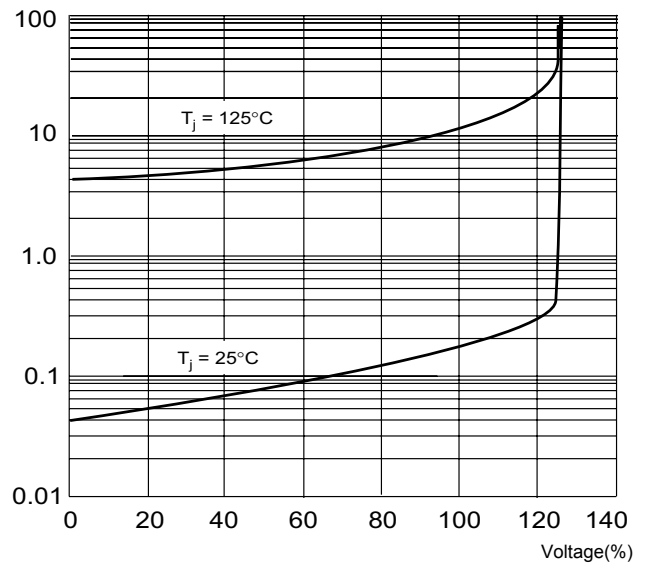
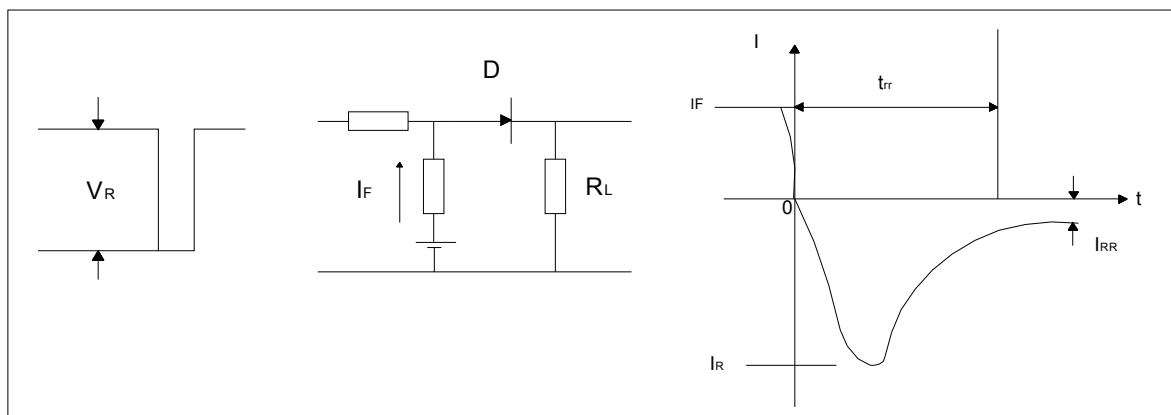
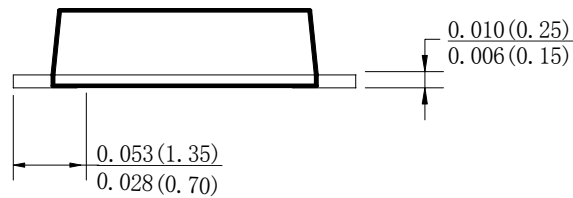
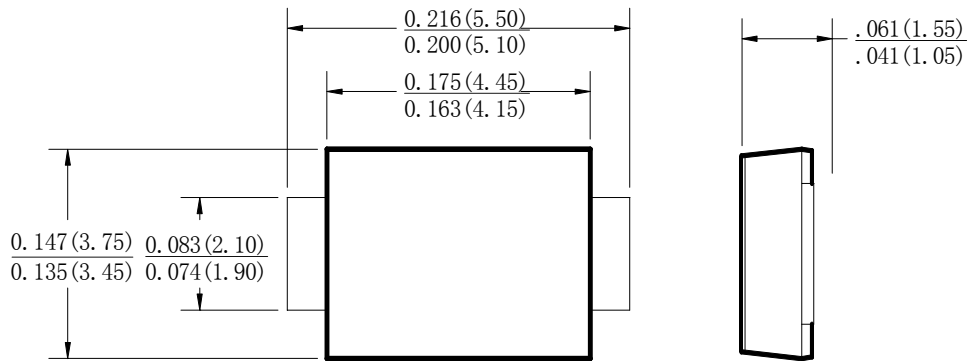

FIG.5: Diagram of circuit and Testing wave form of reverse recovery time



## SMBF Package Outline Dimensions



Dimensions in inches and (millimeters)

## SMBF Suggested Pad Layout

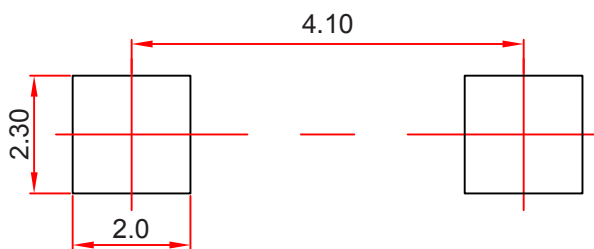

**Note:**

1. Controlling dimension: in millimeters.
2. General tolerance:  $\pm 0.05$ mm.
3. The pad layout is for reference purposes only.