



DO-27 Plastic-Encapsulate Diodes

SB3150 THRU SB3200

Schottky Rectifier Diode

Features

- $I_{F(AV)}$ 3A
- V_{RRM} 150V-20V
- High surge current capability
- Polarity: Color band denotes cathode
- Low peak forward voltage

Applications

- Rectifier

Marking

- SB3150/SB3200

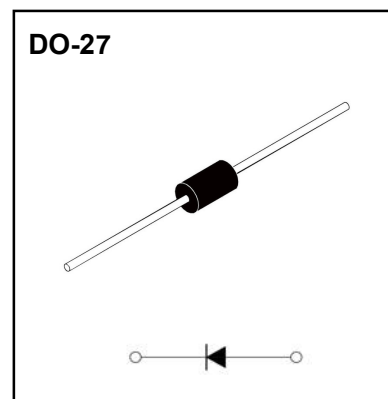

Limiting Values(Absolute Maximum Rating)

Item	Symbol	Unit	Test Conditions	SB3	
				150	200
Repetitive Peak Reverse Voltage	V_{RRM}	V		150	200
Maximum RMS Voltage	V_{RMS}	V		105	140
Maximum DC Blocking Voltage	V_{DC}	V		150	200
Average Forward Current	$I_{F(AV)}$	A	60Hz Half-sine wave, Resistance load, $T_L=100^\circ\text{C}$	3.0	
Surge(Non-repetitive)Forward Current	I_{FSM}	A	60Hz Half-sine wave ,1 cycle , $T_a=25^\circ\text{C}$	80	
Junction Temperature	T_J	$^\circ\text{C}$		-55~+150	
Storage Temperature	T_{STG}	$^\circ\text{C}$		-55 ~ +150	

Electrical Characteristics ($T=25^\circ\text{C}$ Unless otherwise specified)

Item	Symbol	Unit	Test Condition	SB3	
				150	200
MaximumPeak Forward Voltage	V_{FM}	V	$I_{FM}=3.0\text{A}$	0.85	0.95
MaximumPeak Reverse Current	I_{RRM1}	mA	$V_{RM}=V_{RRM}$	$T_a=25^\circ\text{C}$	0.1
	I_{RRM2}			$T_a=100^\circ\text{C}$	2.0
Typical Junction Capacitance	C_J	pF	Measured at 1MHz and applied reverse voltage of 4.0V D.C.	160	
Typical Thermal Resistance	$R_{\theta J-A}$	$^\circ\text{C/W}$	Between junction and ambient	40	
	$R_{\theta J-L}$		Between junction and lead	20	

Typical Characteristics

FIG.1: FORWARD CURRENT DERATING CURVE

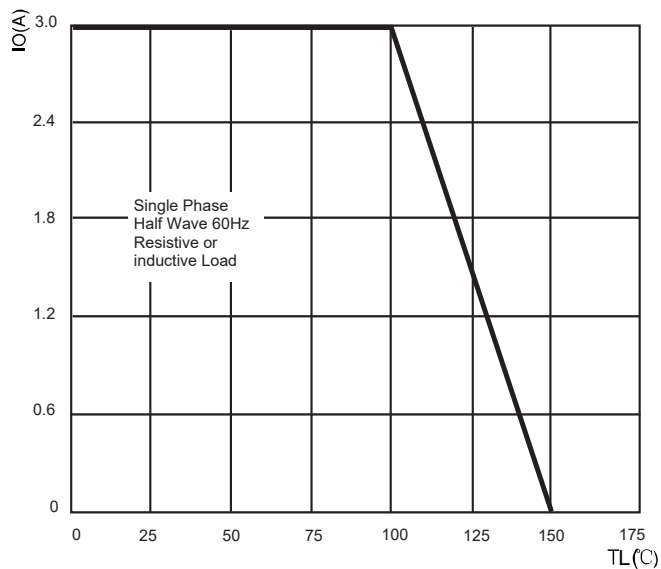

FIG.2: MAXIMUM NON-REPETITIVE FORWARD SURGE CURRENT

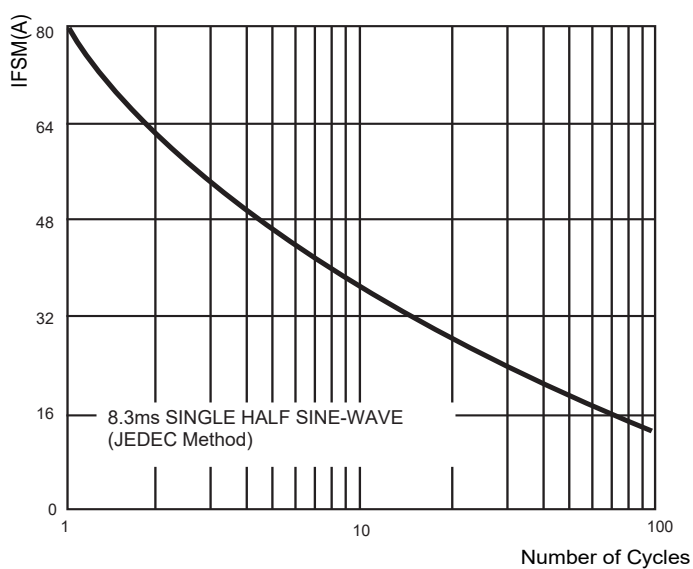

FIG.3: TYPICAL FORWARD CHARACTERISTICS

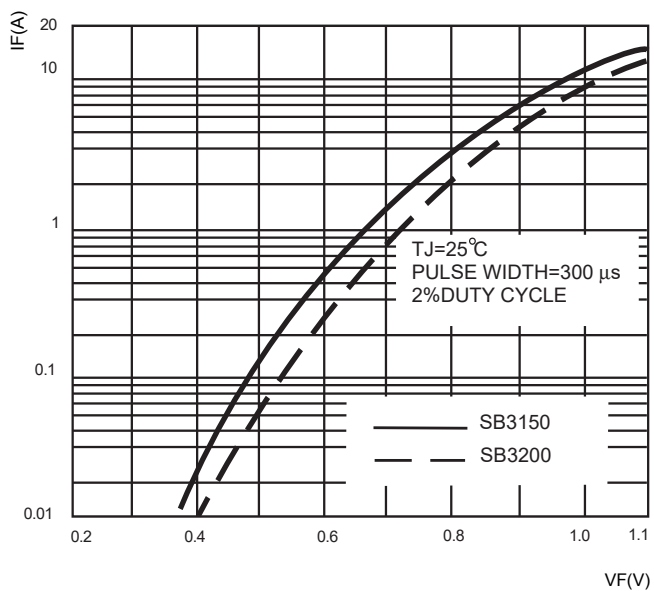
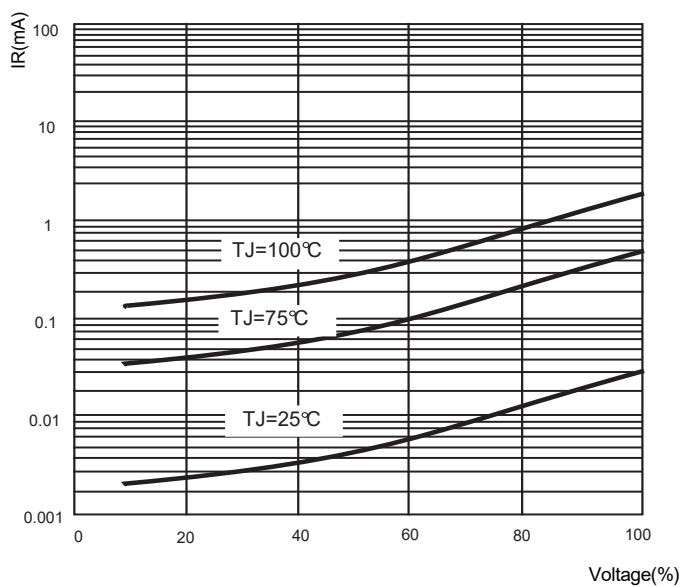
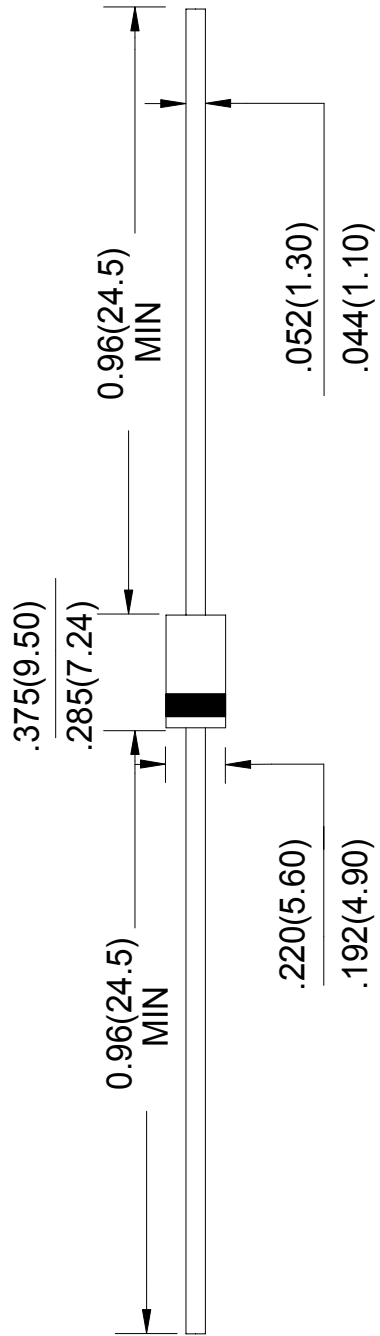

FIG.4: TYPICAL REVERSE CHARACTERISTICS





Unit: in inches (millimeters)

Ammo Box Packaging Specifications For Axial Lead Rectifiers

Axial lead devices are packed in accordance with EIA standard RS-296-D and specifications given below

COMPONENT OUTLINE	COMPONENT PITCH A	INNER TAPE PITCH B	CUMULATIVE PITCH TOLERANCE
	$\pm 0.5\text{mm}(.020'')$	$+0.5\text{mm}(.020'')$	
R-1	5.0mm	26.0mm	2.0mm/20pitch
R-1	5.0mm	52.4mm	2.0mm/10pitch
A-405	5.0mm	26.0mm	2.0mm/20pitch
A-405	5.0mm	52.4mm	2.0mm/10pitch
DO-34/DO-35	5.0mm	26.0mm	2.0mm/20pitch
DO-34/DO-35	5.0mm	52.4mm	2.0mm/10pitch
DO-41	5.0mm	26.0mm	2.0mm/20pitch
DO-41	5.0mm	52.4mm	2.0mm/10pitch
DO-15	5.0mm	52.4mm	2.0mm/10pitch
DO-27	10.0mm	52.4mm	2.0mm/10pitch
R-6	10.0mm	52.4mm	2.0mm/10pitch

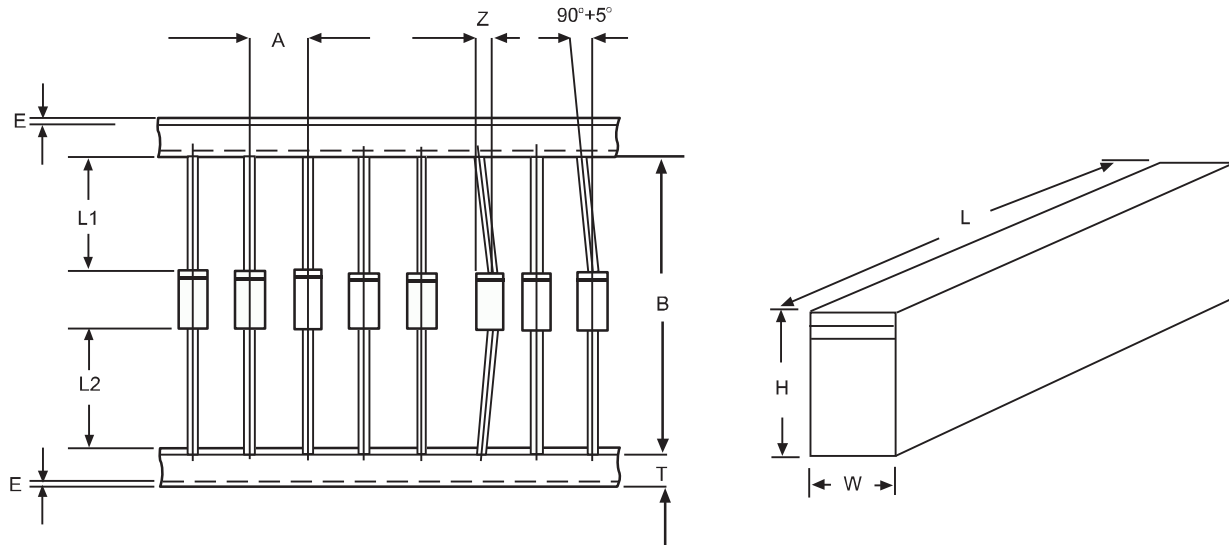

ITEM	SYMBOL	SPECIFICATIONS(mm)	SPECIFICATIONS(inch)
Component alignment	Z	1.2max	0.048max
Tape width	T	6.0 ± 0.4	0.236 ± 0.016
Exposed adhesive	E	0.8max	0.032max
Body eccentricity	$ L1-L2 $	1.0max	0.040max
Box length	L	255.0 ± 5.0	10.04 ± 0.197
Box width	W	78.0 ± 5.0	3.07 ± 0.197
Box height	H	150.0 ± 5.0	5.91 ± 0.197

NOTE: Each component lead shall be sandwiched between tapes for A minimum of 3.2mm(0.126'')